

**TECHNICAL MANUAL
ORGANIZATIONAL MAINTENANCE REPAIR
PARTS AND SPECIAL TOOLS LISTS
FOR**

**MAINTENANCE KITS,
ELECTRONIC EQUIPMENT**

MK-731/ARC-51X

(NSN 6625-00-082-4057)

AND

MK-731A/ARC-51X

(NSN 6625-00-803-1300)

**ORGANIZATIONAL MAINTENANCE REPAIR PARTS
AND SPECIAL TOOLS LISTS
FOR
MAINTENANCE KITS, ELECTRONIC EQUIPMENT
MK-731/ARC-51X (NSN 6625-00-082-4057)
AND
MK-731A/ARC-51X (NSN 6625-00-803-1300)**

Current as of 4 August 1978

REPORTING OF ERRORS

You can improve this manual by recommending improvements using DA Form 2028-2 located in the back of the manual. Simply tear out the self addressed form, fill it out as shown on the sample, fold it where shown, and drop it in the mail.

If there are no blank DA Form 2028-2 in the back of your manual, use the standard DA Form 2028 (Recommended Changes to Publications and Blank Forms) and forward to the Commander, US Army Communications and Electronics Materiel Readiness Command, ATTN: DRSEL-ME-MQ, Fort Monmouth, NJ 07703.

In either case a reply will be furnished direct to you.

Table of Contents

SECTION		Page	Illus Figure
I.	Introduction	1	
II.	Repair parts list	5	
Group	00 Maintenance Kits, Electronic Equipment MK-731/ARC-51X, MK-731A/ARC-51X	5	1-4
	01 Simulator, Test Set, Radio SM-348/ARC-51X, SM-348A/ARC-51X.	13	5
	0101 Amplifier assembly, audio frequency (761-7040-001) (No parts authorized)		
	0102 Amplifier assembly, audio frequency (761-7041-001) (No parts authorized)		
	010201 Amplifier subassembly (761-7047-001) (No parts authorized)		
	0103 Transient blanking assembly (No parts authorized)		
	0104 Test generator, UHF (No parts authorized)		
	0105 Readout assembly	15	6
	0106 Power converter assembly (No parts authorized)		
	02 Test Set, Radio TS-1962/ARC-51X.	17	7
	0201 Test unit	19	8
	0202 Detector assembly (No parts authorized)		

*This manual supersedes TM 11-6625-564-20P, 1 February 1971,

Table of Contents (Cont.)

	Page	Illus Figure
0203 Amplifier assembly, audio frequency (No parts authorized)		
0204 Control, test set	23	9
03 Antenna AS-1484/ARC-51X	25	10
04 Adapter, Connector U-335/ARC-51X	27	11
05 Adapter, Connector U-334/ARC-51X	29	12
06 Dummy Load, Electrical DA-397/ARC-51X	31	13
07 Mounting Tray, Module Extender MT-3372/ARC-51X	33	14
0701 Extender, Module MX-4913/ARC-51X	35	15
0702 Extender, Module MX-4912/ARC-51X	37	16
0703 Extender, Module MX-4911/ARC-51X	39	17
0704 Extender, Module MX-4910/ARC-51X	43	18
0705 Extender, Module MX-4909/ARC-51X	45	19
0706 Extender, Module MX-4908/ARC-51X	47	20
0707 Extender, Module MX-4907/ARC-51X	51	21
0708 Extender, Module MX-4906/ARC-51X	53	22
08 Cable Assembly, Radio Frequency CG-3120/ARC-51X	55	23
09 Cable Assembly, Radio Frequency CG-3119/ARC-51X	57	24
10 Cable Assembly, Radio Frequency CG-3118/ARC-51X	59	25
11 Cable Assembly, Special Purpose, Electrical CX-10191/ARC-51X	61	26
12 Cable Assembly, Special Purpose, Electrical CX-10190/ARC-51X	63	27
13 Cable Assembly, Special Purpose, Electrical CX-10189/ARC-51X	65	28
14 Cable Assembly, Special Purpose, Electrical CX-10188/ARC-51X	67	29
15 Cable Assembly, Special Purpose, Electrical CX-10187/ARC-51X	69	30
16 Cable Assembly, Power, Electrical, Branched CX-10186/ARC-51X	71	31
17 Cable Assembly, Special Purpose, Electrical CX-10185/ARC-51X	73	32
18 Cable Assembly, Radio Frequency CG-1889/U	75	33
19 Cable Assembly, Special Purpose, Electrical CX-9053/ARC-51X	77	34
20 Cable Assembly, Special Purpose, Electrical CX-9052/ARC-51X	79	35
SECTION III. Special tools list (Not applicable)		
IV. National stock number and part number index	80	

SECTION I

INTRODUCTION

1. Scope

This manual lists spares and repair parts; special tools; special test, measurement, and diagnostic equipment (TMDE), and other special support equipment required for performance of organizational maintenance of the MK-731/AR-C-51X, MK-731A/ARC-51X. It authorizes the requisitioning and issue of spares and repair parts as indicated by the source and maintenance codes.

2. General

This Repair Parts and Special Tools List is divided into the following sections:

a. Section II. Repair Parts List. A list of spares and repair parts authorized for use in the performance of maintenance. The list also includes parts which must be removed for replacement of the authorized parts. Parts lists are composed of functional groups in numeric sequence, with the parts in each group listed in figure and item number sequence.

b. Section III. Special Tools List. Not applicable.

c. Section IV. National Stock Number and Part Number Index. A list, in National item identification number (NIIN) sequence, of all National stock numbers (NSN) appearing in the listings, followed by a list, in alphameric sequence, of all part numbers appearing in the listings. National stock numbers and part numbers are cross-referenced to each illustration figure and item number appearance.

3. Explanation of Columns

a. Illustration. This column is divided as follows:

(1) *Figure number.* Indicates the figure number of the illustration on which the item is shown.

(2) *Item Number.* The number used to identify item called out in the illustration.

b. Source, Maintenance, and Recoverability (SMR) Codes.

(1) *Source code.* Source codes indicate the manner of acquiring support items for maintenance, repair, or overhaul of end items. Source codes are entered in the first and second positions of the Uniform SMR Code format as follows:

<i>Code</i>	<i>Definition</i>
PA	Item procured and stocked for anticipated or known usage.
XD	A support item that is not stocked. When required, item will be procured through normal supply channels.

NOTE

Cannibalization or salvage may be used as a source of supply for any items source coded above except those coded XA and aircraft support items as restricted by AR 700-42.

(2) *Maintenance code.* Maintenance codes are assigned to indicate the levels of maintenance authorized to USE and REPAIR support items. The maintenance codes are entered in the third and fourth positions of the Uniform SMR Code format as follows:

(a) The maintenance code entered in the third position will indicate the lowest maintenance level authorized to remove, replace, and use the support item. The maintenance code entered in the third position will indicate one of the following levels of maintenance:

<i>Code</i>	<i>Application/Explanation</i>
O	Support item is removed, replaced, used at the organizational level.

(b) The maintenance code entered in the fourth position indicates whether the item is to be repaired and identifies the lowest maintenance level with the capability to perform complete repair (i.e., all authorized maintenance functions). This position will contain one of the following maintenance codes:

<i>Code</i>	<i>Application/Explanation</i>
O	The lowest maintenance level capable of complete repair of the support item is the organizational level.
H	The lowest maintenance level capable of complete repair of the support item is the general support level.
Z	Nonreparable. No repair is authorized.

(3) *Recoverability Code.* Recoverability codes are assigned to support items to indicate the disposition action on unserviceable items. The recoverability code is entered in the fifth position of the Uniform SMR Code format as follows:

<i>Recoverability codes</i>	<i>Definition</i>
Z	Nonreparable item. When unserviceable, condemn and dispose at the level indicated in position 3.
O	Reparable item. When uneconomically reparable, condemn and dispose at organizational level.

Recoverability

codes
H-Repairable item. When uneconomically repairable, condemn and dispose at the general support level.

Definition

c. National Stock Number. Indicates the National stock number assigned to the item and will be used for requisitioning purposes.

d Part Number. Indicates the primary number used by the manufacturer (individual, Company, firm, corporation, or Government activity), which controls the design and characteristics of the item by means of its engineering drawings, specifications, standards, and inspection requirements to identify an item or range of items.

NOTE

When a stock numbered item is requisitioned, the repair part received may have a different part number than the part being replaced.

e. Federal Supply Code for Manufacturer (FSCM). The FSCM is a 5-digit numeric code listed in SB 708-42 which is used to identify the manufacturer, distributor, or Government agency, etc.

f. Description. Indicates the Federal item name and, if required, a minimum description to identify the item.

g. Unit of Measure (U/M). Indicates the standard of the basic quantity of the listed item as used in performing the actual maintenance function. This measure is expressed by a two-character alphabetical abbreviation (e.g., ea. in, pr, etc). When the unit of measure differs from the unit of issue, the lowest unit of issue that will satisfy the required units of measure will be requisitioned.

h. Quantity Incorporated in Unit. Indicates the quantity of the item used in the breakout shown on the illustration figure, which is prepared for a functional group, subfunctional group, or an assembly.

4. Special Information

a. Usable on codes are shown in the description column. Uncoded items are applicable to all models. Identification of the usable on codes used in this publication are:

<i>Code</i>	<i>Used on</i>
2BH	MK-731/ARC-51X
2CG	MK-731A/ARC-51X

b. The following publication pertains to the MK-731/ARC-51X, MK-731A/ARC-51X and its components:
 TM 11-6625-564-12, Maintenance Kits, Electronic Equipment MK-731/ARC-51X and MK-731A/ARC-51X

c. The illustrations in this manual are identical to those published in TM 11-6625-564-40P. Only those parts assigned the third position SMR maintenance code "C" or "O" are listed in the tabular listing therefore, there may be a break in the item number sequence. Only illustrations containing organizational authorized items appear in this manual.

5. How to Locate Repair Parts

a. When National stock number or part number is unknown.

(1) *First.* Using the table of contents, determine the functional group within which the item belongs. This is necessary since illustrations are prepared for functional groups and listings are divided into the same groups.

(2) *Second.* Find the illustration covering the functional group to which the item belongs.

(3) *Third.* Identify the item on the illustration and note the illustration figure and item number of the item.

(4) *Fourth.* Using the Repair Parts Listing, find the figure and item number noted on the illustration.

b. When National stock number or part number is known.

(1) *First.* Using the Index of National Stock Numbers and Part Numbers, find the pertinent National stock number or part number. This index is in NIIN sequence followed by a list of part numbers in alphameric sequence, cross-referenced to the illustration figure number and item number.

(2) *Second.* After finding the figure and item number, locate the figure and item number in the repair parts list.

6. Abbreviations

Not applicable.

(Next printed page is 4)

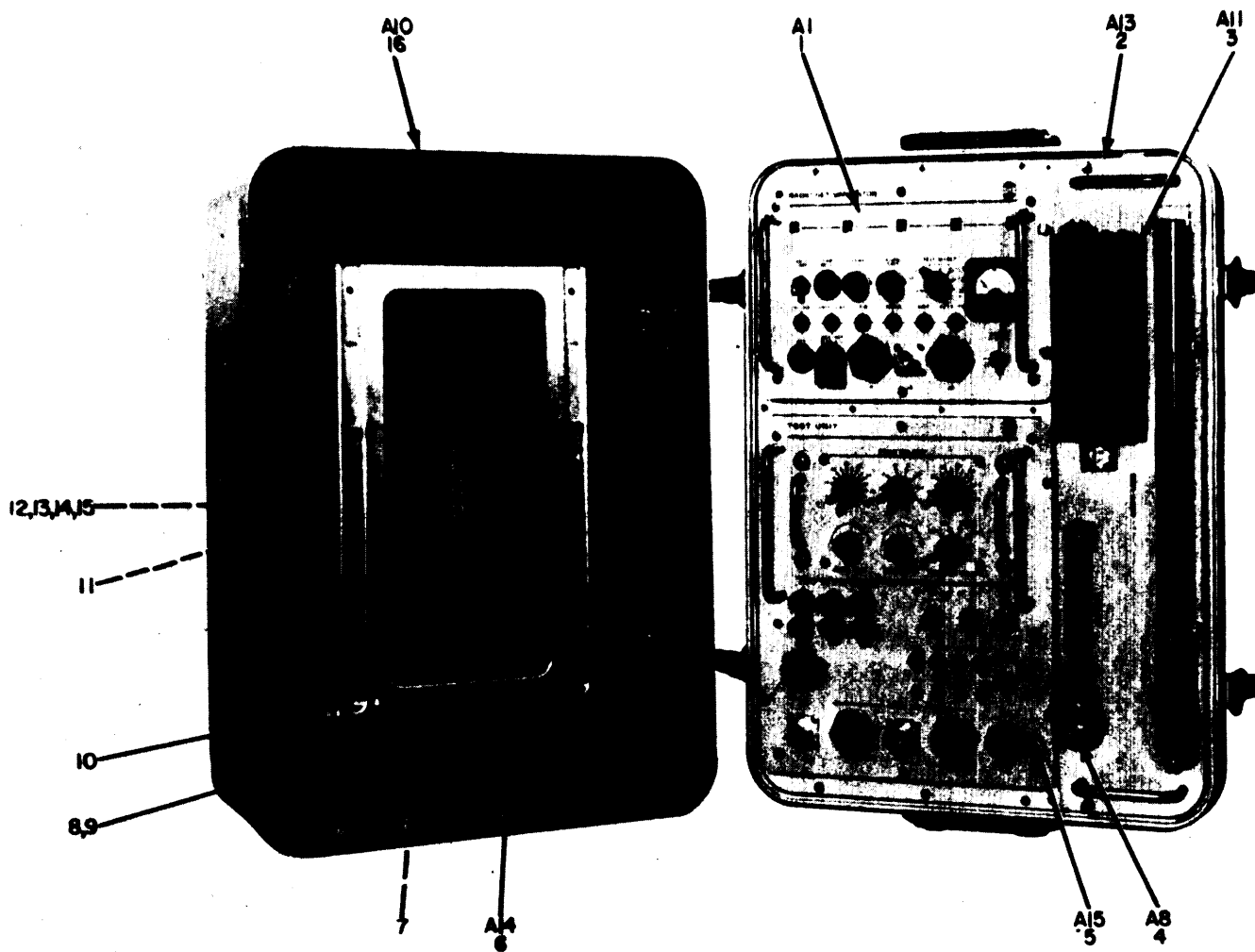

FRONT VIEW , COVER OPEN

NOTE : THE DA-397/ARC-51X IS STORED
IN THE TRANSIT CASE COVER IN
THE MK-731A/ARC-51X.

EL4HK001

Figure 1. Maintenance Kit, Electronic Equipment MK-731/ARC-51X and MK-731A/ARC-51X
(Sheet 1 of 3).

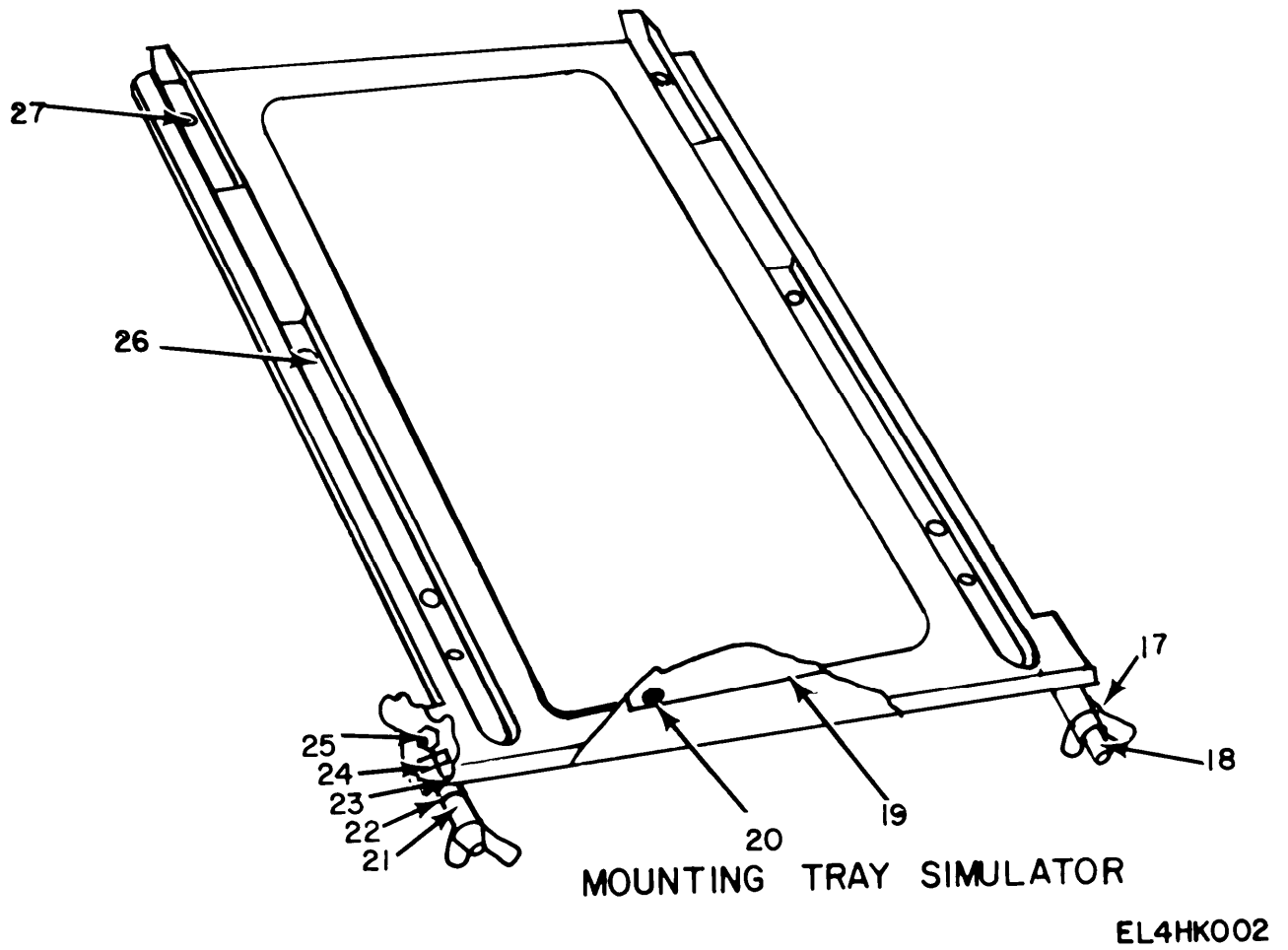
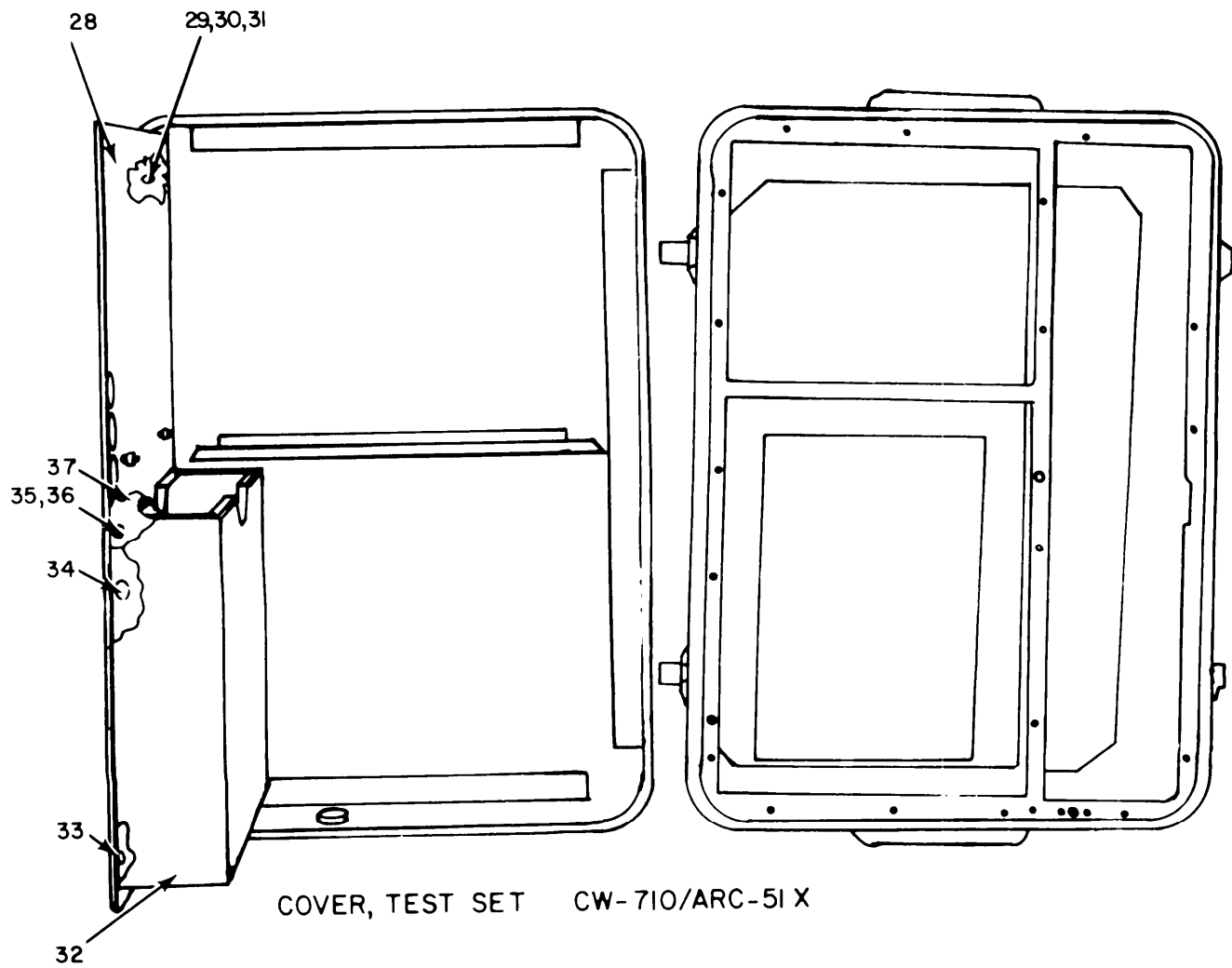

Figure 1. Maintenance Kit, Electronic Equipment MK-731/ARC-51X and MK-731A/ARC-51X (Sheet 2 of 3).



EL4HK003

Figure 1. Maintenance Kit, Electronic Equipment MK-731/ARC-51X and MK-731A/ARC-51X (Sheet 3 of 3).

(1) ILLUSTRATION (A) FIG NO	(2) (B) ITEM NO	(3) SMR CODE	(4) NATIONAL STOCK NUMBER	(5) PART NUMBER	(6) FSCM	(6) DESCRIPTION	USABLE ON CODE	(7) U/M	(8) QTY INC IN UNIT
GROUP 00 MAINTENANCE KIT,ELECTRONIC									
EQUIPMENT MK-731/ARC-51X AND									
MK-731A/ARC-51X									
1	1	PAOHH	6625-00-738-5973	SM348ARC51X	80058	SIMULATOR,TEST SET		EA	1
1	1	PAOHH	6625-00-089-7164	SM348AARC51X	80058	SIMULATOR,TEST SET	2CG	EA	1
1	2	XDOOO		MT3372ARC51X	80058	MOUNTING TRAY,MODUL		EA	1
1	3	PAOOO	6625-00-738-5991	DA397ARC51X	80058	DUMMY LOAD,ELECTRIC		EA	1
1	4	PAOOO	5985-00-726-2290	AS1484ARC51X	80058	ANTENNA		EA	1
1	5	PAOOO	6625-00-965-1483	TS1962ARC51X	80058	TEST SET,RADIO		EA	1
1	6	PAOOO	6625-00-738-5976	MT3371ARC51X	80058	MOUNTING TRAY,SIMUL		EA	1
1	7	PAOOO	5180-00-738-6019	TK155ARC51X	80058	TOOL KIT,RADIO SET		EA	1
1	11	XDOZZ		757-9783-000	13499	PLATE, IDENT		EA	1
1	12	PAOZZ	5310-00-938-2013	MS35649-24	96906	NUT,PLAIN,HEXAGON		EA	4
1	13	PAOZZ	5305-00-054-5638	MS51957-4	96906	SCREW,MACHINE		EA	4
1	14	PAOZZ	5310-00-907-0959	310-6320-000	79807	WASHER,FLAT		EA	4
1	15	PAOZZ	5310-00-928-2690	MS35338-134	96906	WASHER,LOCK		EA	4
1	17	PAOZZ	5310-00-550-3715	MS35333-70	96906	WASHER,LOCK		EA	2
1	18	PAOZZ	5306-00-924-0654	547-1646-002	13499	BOLT,TEE HEAD		EA	2
1	19	XDOZZ		767-0754-008	13499	PLATE, IDENT		EA	1
1	20	PAOZZ	5310-00-938-2013	MS35649-24	96906	NUT,PLAIN,HEXAGON		EA	2
1	21	XDOZZ		756-9043-001	13499	SPACER,SLEEVE		EA	4
1	22	PAOZZ	5365-00-695-2558	340-0642-00	91314	RING,RETAINING		EA	4
1	23	XDOZZ		547-1647-002	13499	PIN,STRAIGHT,HEADLE		EA	2
1	24	PAOZZ	5310-00-881-1624	334-1656-00	06164	NUT,PLAIN,HEXAG		EA	2
1	25	PAOZZ	3040-00-016-2719	547-1643-002	13499	BALL,BALL JOINT		EA	2
1	26	PAOZZ	5305-00-054-6672	MS51957-47	96906	SCREW,MACHINE		EA	4
1	27	PAOZZ	5305-00-764-2966	MS51959-2	96906	SCREW,MACHINE		EA	4

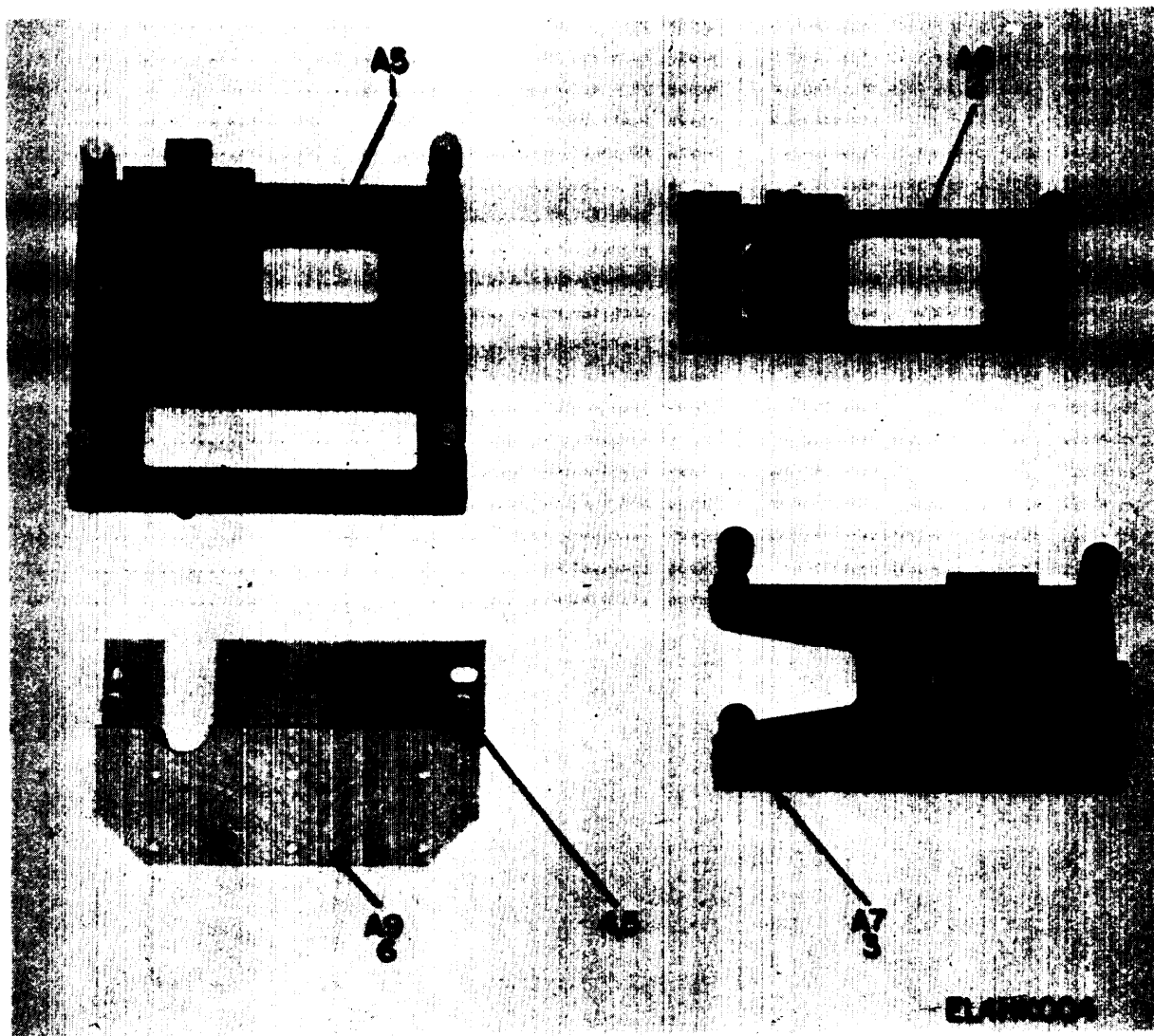

Figure 2. Maintenance Kit, Electronic Equipment MK-731/ARC-51X and MK-731A/ARC-51X, Alignment Fixtures and Locking Block.

SECTION II

(1)	(2)	(3)	(4)	(5)	(6)	(7)	(8)	
ILLUSTRATION							QTY	
(A)	(B)	NATIONAL			DESCRIPTION		INC	
FIG	ITEM	SMR	STOCK	PART			IN	
NO	NO	CODE	NUMBER	NUMBER	FSCM	USABLE ON CODE	U/M	UNIT
2	1	PAOZZ	6625-00-738-5989	MX6733ARC51X	80058	ALIGNMENT FIXTURE	EA	1
2	2	PAOZZ	6625-00-738-5986	MX6734ARC51X	80058	ALIGNMENT FIXTURE	EA	1
2	3	PAOZZ	6625-00-738-5990	MX6732ARC51X	80058	ALIGNMENT FIXTURE	EA	1
2	4	PAOZZ	5305-00-054-5651	MS51957-17	96906	SCREW,MACHINE	EA	2
2	5	PAOZZ	5365-00-717-8566	340-0644-00	91314	SLEEVE,SPRING	EA	2
2	6	PAOOO	6625-00-738-5984	MX6731ARC51X	80058	BLOCK,LOCKING	EA	1

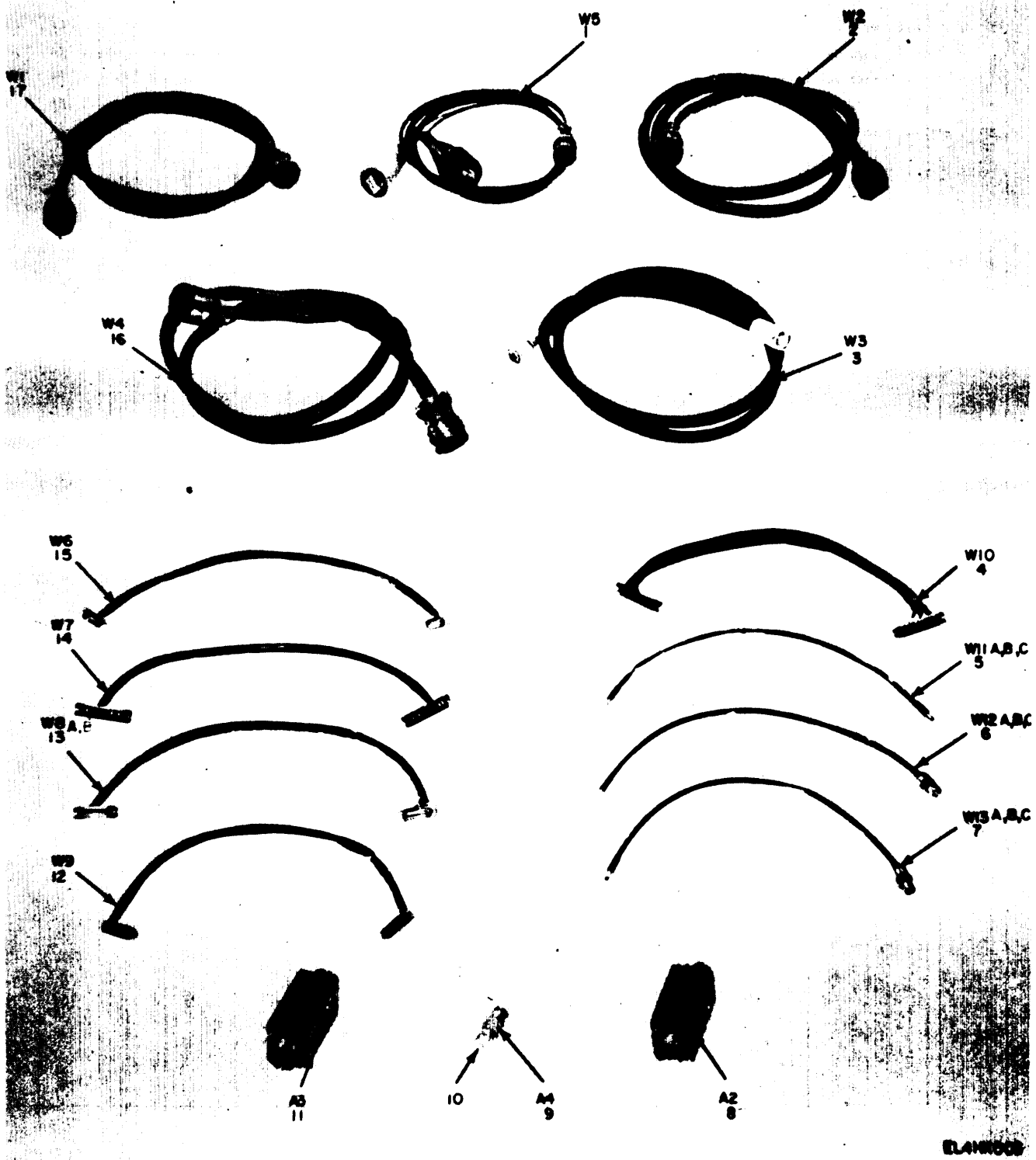
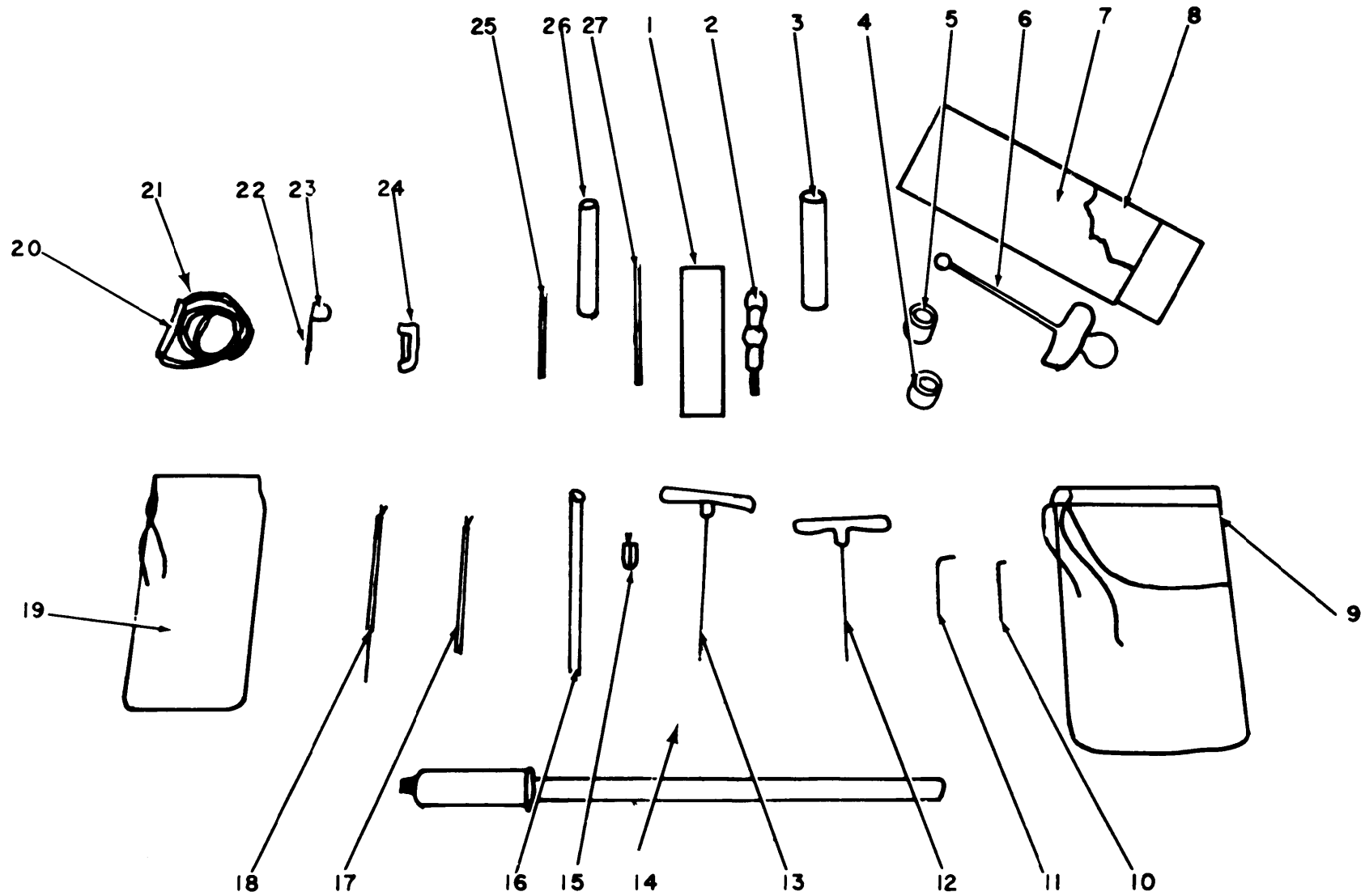

Figure 3. Maintenance Kit, Electronic Equipment MK-731/ARC-51X and MK-731A/ARC-51X, Cable Assemblies and Adapters.

SECTION II

(1) ILLUSTRATION (A) FIG NO	(2) (B) ITEM NO	(3) SMR CODE	(4) NATIONAL STOCK NUMBER	(5) PART NUMBER	(6) DESCRIPTION FSCM	(7) USABLE ON CODE	(8) QTY INC IN UNIT
3	1	PAOOO	6625-00-738-5985	CX10186ARC51X	80058 CABLE ASSEMBLY	EA	1
3	2	PAOOO	6625-00-985-8083	CX9053ARC51X	80058 CABLE ASSEMBLY,SPEC	EA	1
3	3	PAOOO	5995-00-467-3887	CG1889U5FT	80058 CABLE ASSEMBLY,RADI	EA	1
3	4	PAOOO	5995-00-985-8081	CX10191ARC51X	80058 CABLE ASSEMBLY,SPEC	EA	1
3	5	PAOOO	6625-00-985-8078	CG3118ARC51X	80058 CABLE ASSEMBLY,RADI	EA	3
3	6	PAOOO	6625-00-985-8079	CG3119ARC51X	80058 CABLE ASSEMBLY,RADI	EA	3
3	7	PAOOO	6625-00-985-8080	CG3120ARC51X	80058 CABLE ASSEMBLY,RADI	EA	3
3	8	PAOOO	5935-00-762-9306	U335ARC51X	80058 ADAPTER,TEST	EA	1
3	9	PAOOO	5935-01-035-5650	U336ARC51X	80058 ADAPTER,CONNECTOR	EA	1
3	10	PAOZZ	5935-00-643-9875	UG29BU	30058 ADAPTER,CONNECT	EA	1
3	11	PAOOO	5935-00-762-9307	U334ARC51X	80058 ADAPTER,CONNECTOR	EA	1
3	12	PAOOO	6625-00-985-8088	CX10190ARC51X	80058 CABLE ASSEMBLY,SPEC	EA	1
3	13	PAOOO	6625-00-935-8641	CX10189ARC51X	80058 CABLE ASSY,SP,E	EA	2
3	14	PAOOO	6625-00-985-8086	CX10188ARC51X	80058 CABLE ASSEMBLY,SPEC	EA	1
3	15	PAOOO	6625-00-985-8085	CX10187ARC51X	80058 CABLE ASSEMBLY,SPEC	EA	1
3	16	PAOOO	6625-00-985-8084	CX10185ARC51X	80058 CABLE ASSEMBLY,SPEC	EA	1
3	17	PAOOO	6625-00-985-8082	CX9052ARC51X	80058 CABLE ASSEMBLY,SPEC	EA	1



**NOTE: FOR COMPLETE REFERENCE DESIGNATION
PREFIX WITH A16.**

EL4HK006

Figure 4. Maintenance Kit, Electronic Equipment MK-731/ARC-51X and MK-731A/ARC-51X, Tool Kit, Radio Set.

SECTION II

(1) ILLUSTRATION (A) FIG NO	(2) (B) ITEM NO	(3) SMR CODE	(4) NATIONAL STOCK NUMBER	(5) PART NUMBER	(6) FSCM	(6) DESCRIPTION	(7) USABLE ON CODE	(8) QTY INC IN UNIT
4	1	PAOZZ	5120-00-152-2516	761-5944-001	13499	CUSHION EXTENSION	EA	1
4	2	PAOZZ	5120-00-963-7661	CETC6B	71468	REMOVAL TOOL, CONNE	EA	1
4	3	PAOZZ	5140-00-152-2514	024-0628-020	13499	CONTAINER, TOOL	EA	1
4	4	PAOZZ	5120-00-906-6377	756-7580-001	13499	SOCKET WRENCH	EA	1
4	5	PAOZZ	5120-00-906-6379	756-7579-001	13499	SOCKET WRENCH	EA	1
4	6	PAOZZ	5120-00-618-4433	F10-1	26848	WRENCH, TORQUE	EA	1
4	7	PAOZZ	5140-00-944-7206	761-5947-001	13499	CASE TORQUE WRENCH	EA	1
4	8	PAOZZ	5140-00-944-7205	761-5945-001	13499	COVER TORQUE WRENCH	EA	1
4	9	XDOZZ		024-0642-010	13499	BAG, COTTON DUCK	EA	1
4	10	PAOZZ	5120-00-908-4752	544-8398-002	13499	KEY, SOCKET HEAD SCR	EA	1
4	11	PAOZZ	5120-00-952-0108	GT1003	70276	KEY, SCH, SCREW	EA	1
4	12	PAOZZ	5120-00-995-9045	GGGK275	81348	KEY, SCH, SCREW	EA	1
4	13	PAOZZ	5120-00-198-5401	050	08664	KEY, SCH, SCREW	EA	1
4	14	PAOZZ	4320-00-854-4444	6A49450	53800	PUMP, INFLATING	EA	1
4	15	PAOZZ	5935-00-959-1457	544-8352-002	13499	SHIELD, ELECTRICAL C	EA	1
4	16	PAOZZ	4910-00-908-6709	7229	17875	GAUGE, PRESSURE	EA	1
4	17	PAOZZ	5120-00-720-1908	024-0168-00	13499	ALIGNMENT TOOL, ELEC	EA	1
4	18	PAOZZ	5120-00-013-7117	548-9286-002	13499	ALIGNMENT TOOL, ELEC	EA	1
4	19	PAOZZ	8105-00-753-4589	024-0137-00	13499	BAG, COTTON DUCK	EA	1
4	20	PAOZZ	5935-00-617-6837	SKT10WHT	98291	JACK, TIP	EA	1
4	21	PAOZZ	5935-00-990-6983	203B	83330	PLUG, TIP	EA	1
4	22	PAOZZ	5315-00-297-0875	MS171444	96906	PIN, SPRING	EA	1
4	23	PAOZZ	5120-00-022-7793	548-2214-002	13499	ALIGNMENT TOOL, ROTO	EA	1
4	24	PAOZZ	5120-00-906-6380	756-7571-001	13499	ANVIL	EA	1
4	25	PAOZZ	5120-00-906-6376	553-9709-002	13499	PIN, DRIFT	EA	
4	26	PAOZZ	5140-00-906-6373	024-0628-010	13499	CONTAINER, TOOL	EA	1
4	27	PAOZZ	5120-00-908-4754	544-8357-002	13499	ALIGNMENT TOOL	EA	1

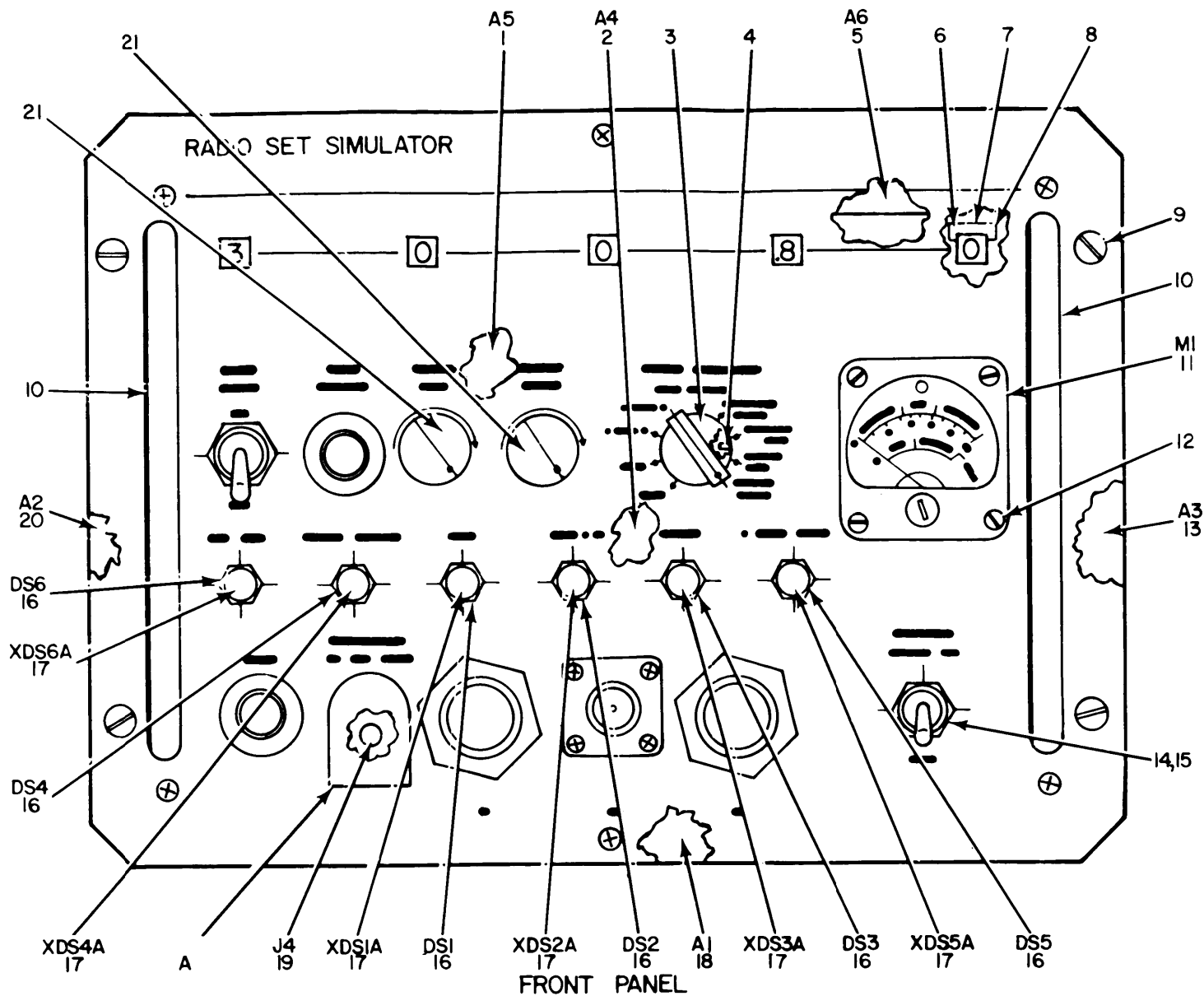

NOTE: FOR COMPLETE REFERENCE
DESIGNATION PREFIX WITH A1.

Figure 5. Simulators, Test Set, Radio SM-348/ARC-51X and SM-348A/ARC-51X.

EL4HK007

SECTION II

(1) ILLUSTRATION (A) FIG NO	(2) (B) ITEM NO	(3) SMR CODE	(4) NATIONAL STOCK NUMBER	(5) PART NUMBER	(6) FSCM	(7) DESCRIPTION USABLE ON CODE	(8) QTY INC IN U/M UNIT
GROUP 01 SIMULATOR, TEST SET, RADIO SM-348/ARC-51X							
AND SM-348A/ARC-51X							
5	1	PAOHH	6625-00-906-6366	761-7044-001	13499	TESTGENERATOR, ULTRA 2BH	EA 1
5	1	PAOHH	6625-00-143-6716	775-2711-001	13499	GENERATOR, SIGNAL 20G	EA 1
5	2	PAOHH	6625-00-908-7393	761-7043-001	13499	TRANSIENTBLANKER	EA 1
5	3	PAOZZ	5355-00-908-4763	757-0230-001	13499	KNOB	EA 1
5	4	PAOZZ	5305-00-719-5342	MS51981-26	96906	SETScrew	EA 6
5	5	PAOHH	6625-00-906-6367	761-7062-001	13499	READCUT	EA 1
5	13	PAOHH	6625-00-908-7386	761-7042-001	13499	CONVERTER, POWER	EA 1
5	16	PAOZZ	6240-00-155-7836	MS25237-327	96906	LAMP, INCANDESCENT	EA 6
5	17	PAOZZ	6210-00-767-6246	855020R	08717	LEN, LID, LIGHT	EA 6
5	18	PAOHH	6625-00-906-6365	761-7040-001	13499	AMPLIFIER, AUDIO FRE	EA 1
5	20	PAOHH	6625-00-908-7385	761-7041-001	13499	AMPLIFIER, AUDIO FRE	EA 1
5	21	PAOZZ	5355-00-909-0465	757-0228-001	13499	KNOB	EA 2

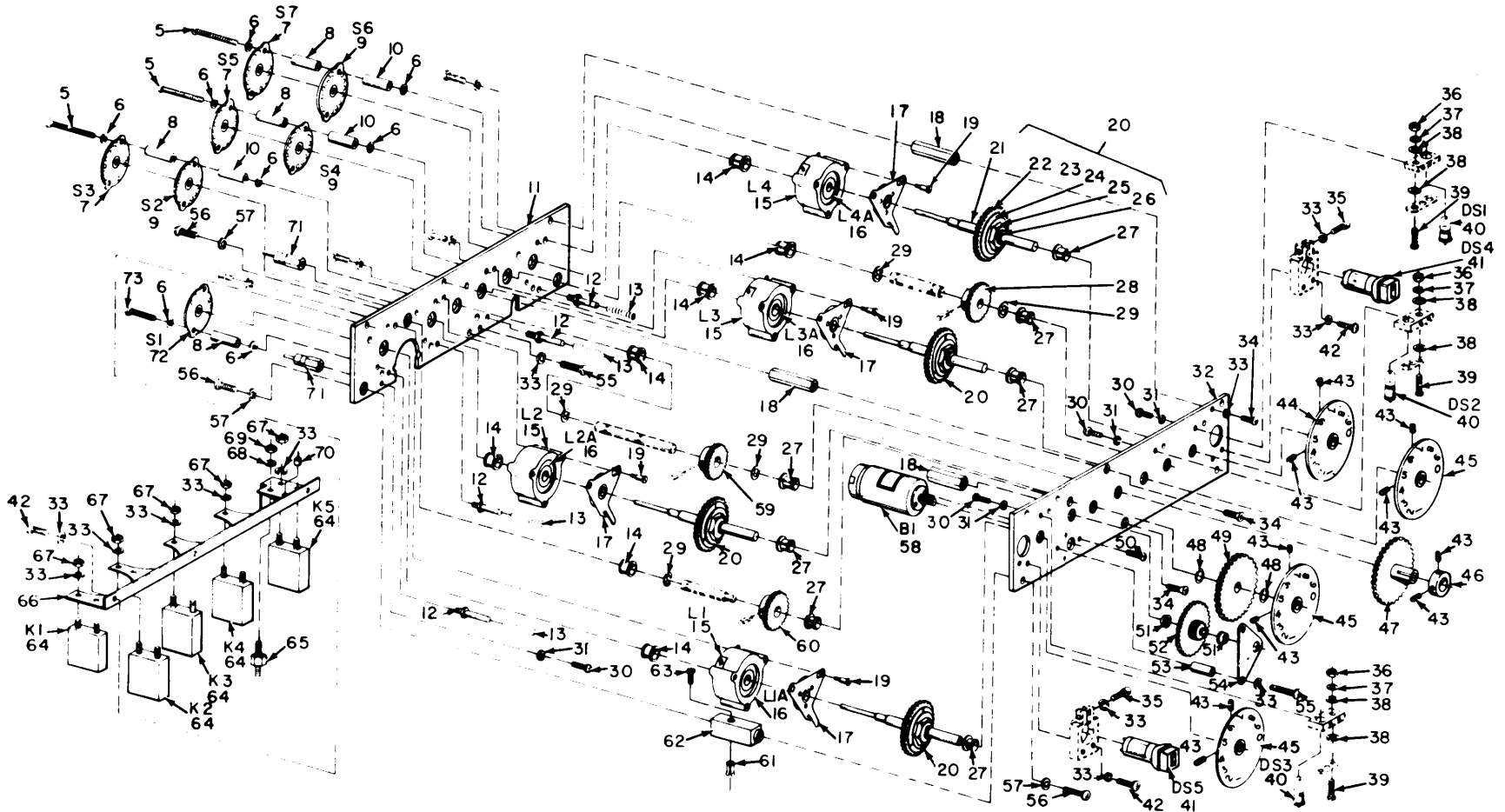

EXPLODED VIEW

NOTE: FOR COMPLETE REFERENCE DESIGNATION
PREFIX WITH AIA6.

EL4HK019

SECTION II

(1)	(2)	(3)	(4)	(5)	(6)	(7)	(8)	
ILLUSTRATION							QTY	
(A)	(B)		NATIONAL		DESCRIPTION		INC	
FIG	ITEM	SMR	STOCK	PART			IN	
NO	NO	CODE	NUMBER	NUMBER	FSCM	USABLE ON CODE	U/M	UNIT

GROUP 0105 READOUT ASSEMBLY

6	40	PAOZZ	6240-00-155-7836	MS25237-327	96906	LAMP, INCANDESCENT	EA	3
---	----	-------	------------------	-------------	-------	--------------------	----	---

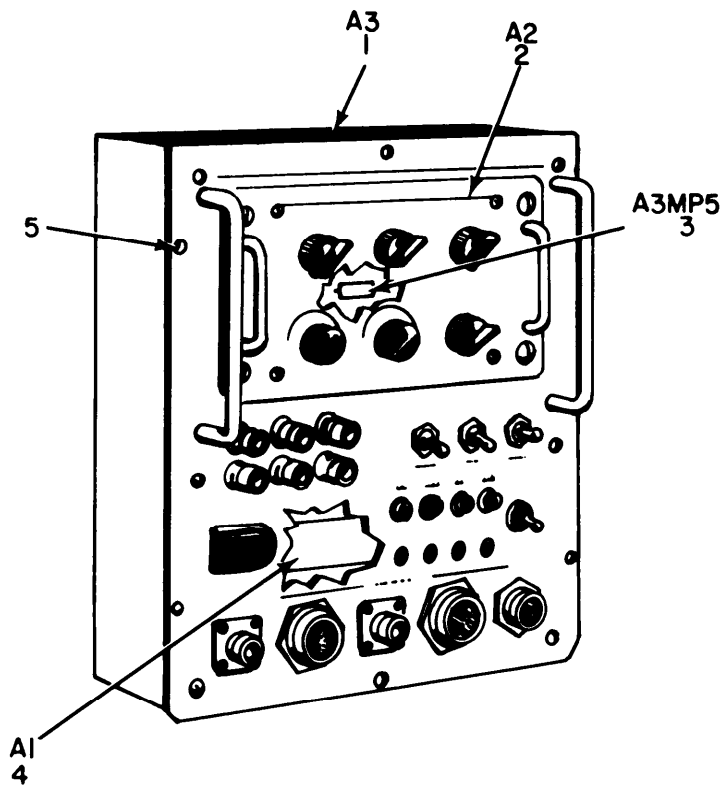

NOTE:
FOR COMPLETE REFERENCE DESIGNATION
PREFIX WITH A15

EL4HK022

Figure 7. Test Set, Radio TS-1962/ARC-51X.

SECTION II

(1)	(2)	(3)	(4)	(5)	(6)	(7)	(8)	
ILLUSTRATION							QTY	
(A)	(B)	NATIONAL			DESCRIPTION		INC	
FIG	ITEM	SMR	STOCK	PART			IN	
NO	NO	CODE	NUMBER	NUMBER	FSCM	USABLE ON CODE	U/M	UNIT

GROUP 02 TEST SET,RADIO TS-1962/ARC-51X

7	1	XDOHH		761-7064-001	13499	TEST UNIT	EA	1
7	2	PAOOO	6625-00-908-7390	761-7066-001	13499	CONTROL,TESTSET	EA	1
7	3	PAOHH	5821-00-908-4758	761-7069-001	13499	DETECTOR,AUDIO FREQ	EA	1
7	4	PAOHH	6625-00-908-7384	761-7065-001	13499	AMPLIFIER,AUDIO FRE	EA	1

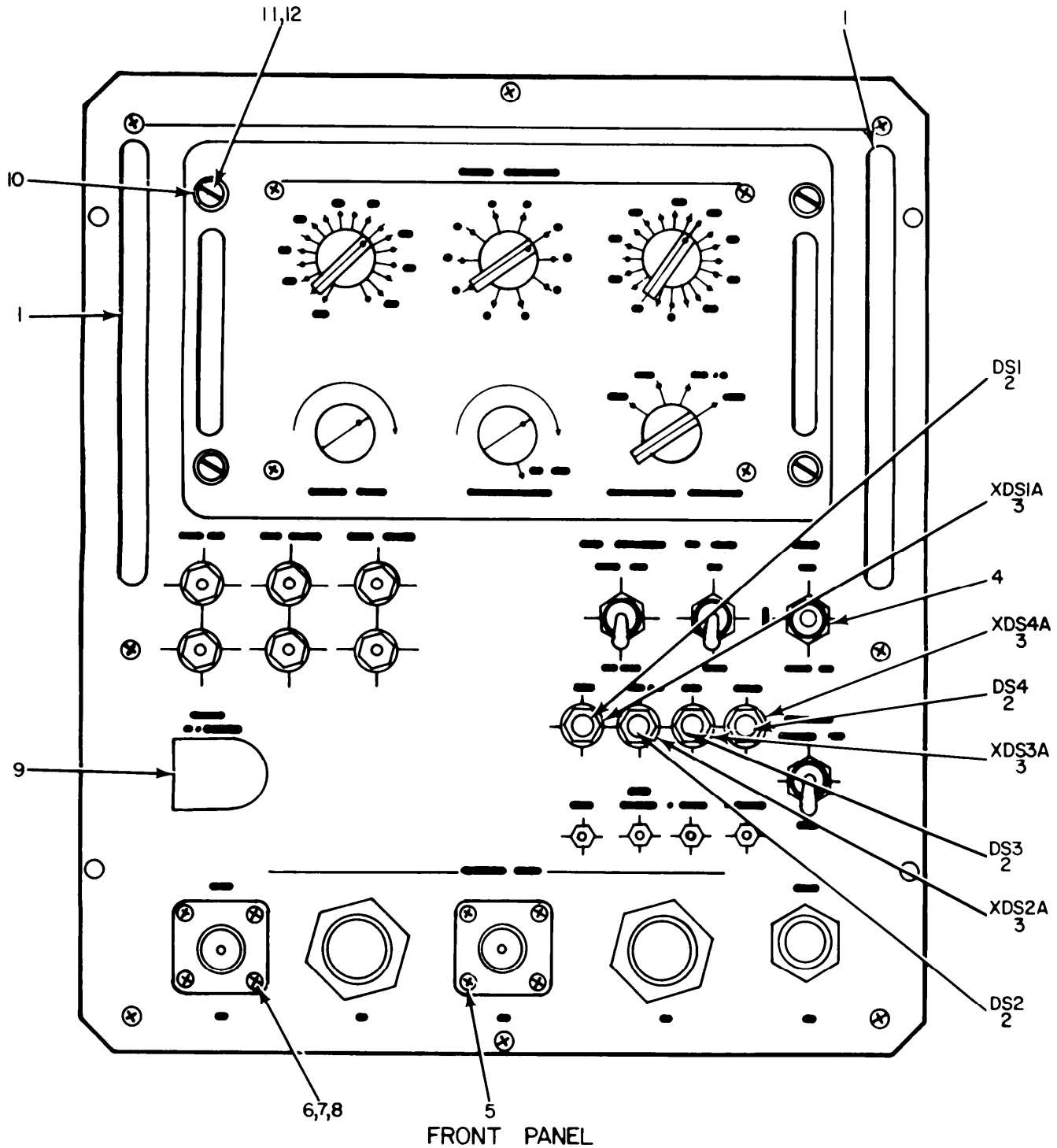

NOTE: FOR COMPLETE REFERENCE
DESIGNATION PREFIX WITH AI5A3.

EL4HK023

Figure 8. Test Unit

SECTION II

(1)	(2)	(3)	(4)	(5)	(6)	(7)	(8)	
ILLUSTRATION							QTY	
(A)	(B)		NATIONAL		DESCRIPTION		INC	
FIG	ITEM	SMR	STOCK	PART			IN	
NO	NO	CODE	NUMBER	NUMBER	FSCM	USABLE ON CODE	U/M	UNIT

GROUP 0201 TEST UNIT

8	2	PAOZZ	6240-00-155-7836	MS25237-327	96906	LAMP, INCANDESCENT	EA	4
8	3	PAOZZ	6210-00-767-6246	855020R	08717	LENS, IND, LIGHT	EA	4

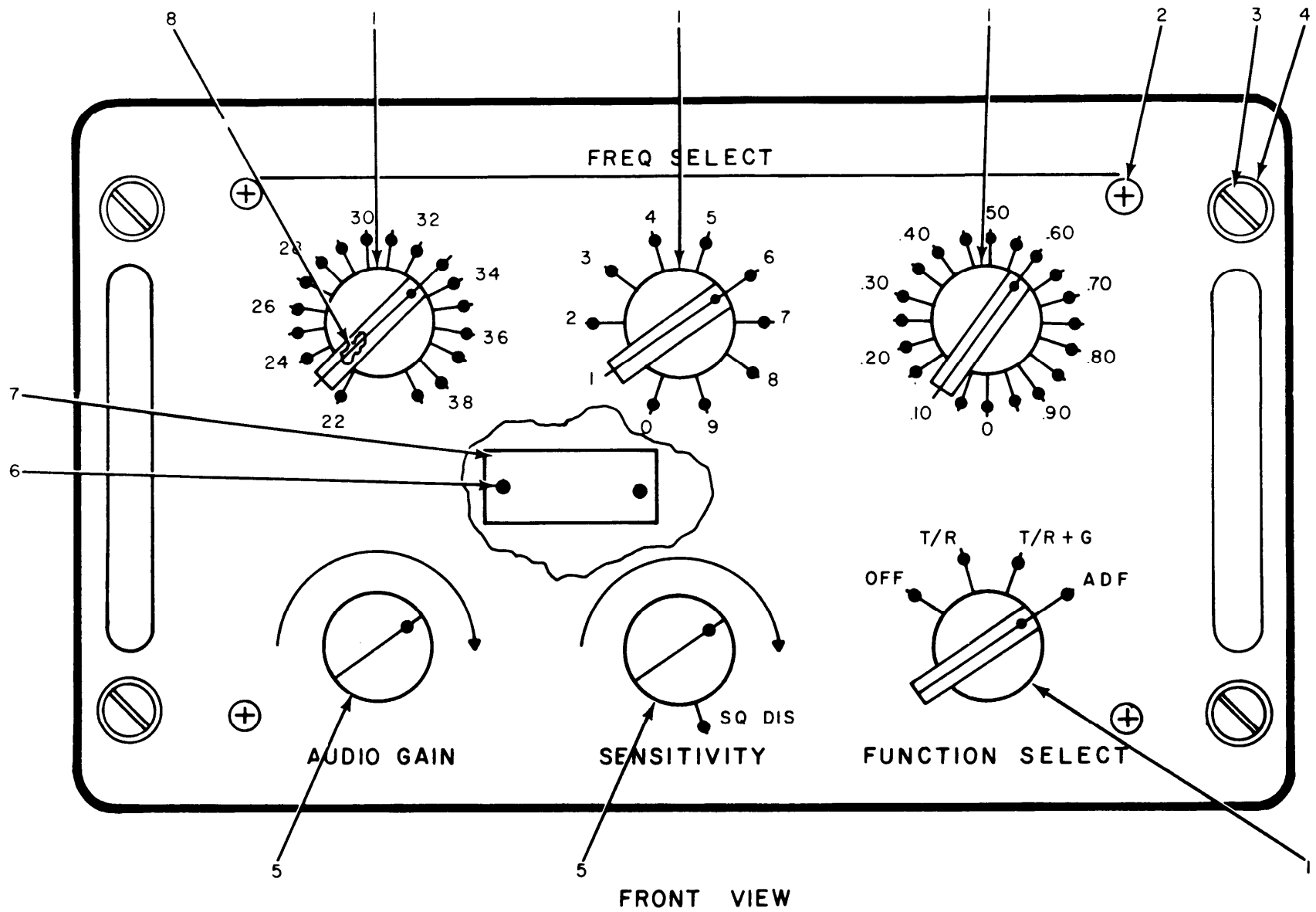

NOTE: FOR COMPLETE REFERENCE DESIGNATION PREFIX WITH AI5A2.

Figure 9. Control, Test Set (Sheet 1 of 2).

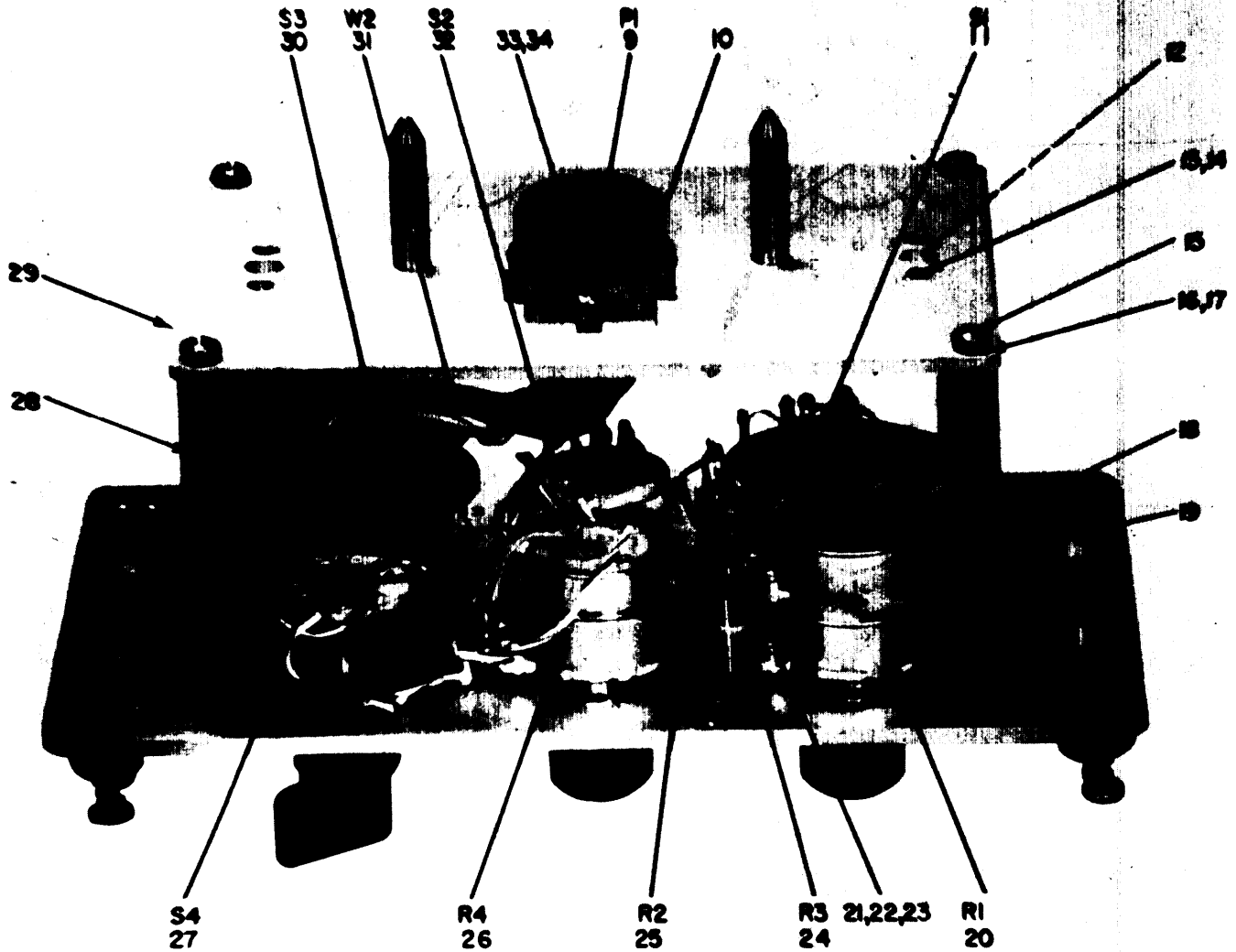

NOTE FOR COMPLETE REFERENCE DESIGNATION PREFIX WITH AISA2

INTERNAL VIEW

EL4HK030

Figure 9. Control, Test Set (Sheet 2 of 2).

SECTION II

(1) ILLUSTRATION (A) FIG NO	(2) (B) ITEM NO	(3) SMR CODE	(4) NATIONAL STOCK NUMBER	(5) PART NUMBER	(6) FSCM	DESCRIPTION	USABLE ON CODE	(7) U/M	(8) QTY INC IN UNIT
GROUP 0204 CONTROL, TEST SET									
9	1	PAOZZ	5355-00-702-2704	757-0231-001	13499	KNOB		EA	4
9	2	PAOZZ	5305-00-054-6652	MS51957-28	96906	SCREW, MACHINE		EA	4
9	3	PAOZZ	5325-00-290-3969	2600-B	71286	STUD ASSEMBLY, TURN		EA	4
9	4	PAOZZ	5310-00-639-7435	2600SW2	13499	WASHER, SPLIT		EA	4
9	5	PAOZZ	5355-00-909-0465	757-0228-001	13499	KNOB		EA	2
9	6	PAOZZ	5305-00-054-5635	MS51957-1	96906	SCREW, MACHINE		EA	2
9	7	XDOZZ		767-0745-000	13499	PLATE, IDENT		EA	1
9	8	PAOZZ	5305-00-719-5342	MS51981-26	96906	SETSCREW		EA	12
9	9	PAOZZ	5935-00-906-6335	756-8841-001	13499	CONNECTOR, RECEPTACL		EA	1
9	10	XDOZZ		756-8846-001	13499	PLATE, POSN, CONN		EA	1
9	11	PAOZZ	5930-00-944-9837	237164RK1	76854	SWITCH, ROTARY		EA	1
9	12	PAOZZ	5325-00-285-3373	012-1194-00	13499	LOCKSPRING TURN		EA	2
9	13	PAOZZ	5310-00-938-2013	MS35649-24	96906	NUT, PLAIN, HEXAGON		EA	4
9	14	PAOZZ	5305-00-764-2964	MS51959-4	96906	SCREW, MACHINE		EA	4
9	15	PAOZZ	5305-00-054-6651	MS51957-27	96906	SCREW, MACHINE		EA	5
9	16	PAOZZ	5310-00-907-0959	310-6320-000	79807	WASHER, FLAT		EA	4
9	17	PAOZZ	5310-00-928-2690	MS35338-134	96906	WASHER, LOCK		EA	16
9	18	XDOZZ		756-8834-002	13499	POST, ELMCH		EA	2
9	19	PAOZZ	5305-00-763-6962	MS51959-27	96906	SCREW, MACHINE		EA	4
9	20	PAOZZ	5905-00-954-6432	NX24429	71450	RESISTOR, VARIABLE, N		EA	1
9	21	PAOZZ	5310-00-275-5147	P334-4120-00	77250	NUT, PLAIN, HEXAGON		EA	6
9	22	XDOZZ		505-1504-001	13499	WASHER, FLAT		EA	6
9	23	PAOZZ	5310-00-883-5931	410894-38	96214	WASHER, LOCK		EA	6
9	24	PAOZZ	5905-00-171-1975	RC42GF151K	81349	RESISTOR, FIXED, COMP		EA	1
9	25	PAOZZ	5905-00-279-1756	RC20GF151K	81349	RESISTOR, FIXED, COMP		EA	1
9	26	PAOZZ	5905-00-954-6899	NX24427	71450	RESISTOR, VARIABLE, N		EA	1
9	27	PAOZZ	5930-00-944-9835	236923BA1	76854	SWITCH, ROTARY		EA	1
9	28	XDOZZ		756-8835-002	13499	POST, ELMCH		EA	2
9	29	XDOZZ		756-8837-002	13499	PLATE, RETAINING		EA	1
9	30	PAOZZ	5930-00-944-9836	238191RK2	76854	SWITCH, ROTARY		EA	1
9	31	XDOOO		761-7078-001	13499	WIRING HARNESS		EA	1
9	32	PAOZZ	5930-00-944-9838	236922BA1	76854	SWITCH, ROTARY		EA	1
9	33	PAOZZ	5310-00-515-8243	310-0046-00	79807	WASHER, FLAT		EA	1
9	34	PAOZZ	5310-00-929-6395	MS35338-136	96906	WASHER, LOCK		EA	5

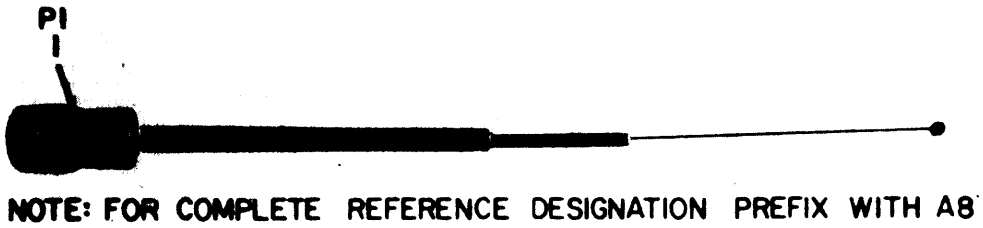

EL4HK03I

Figure 10. Antenna AS-1484/ARC-51X.

SECTION II

(1)	(2)	(3)	(4)	(5)	(6)	(7)	(8)	
ILLUSTRATION							QTY	
(A)	(B)	NATIONAL			DESCRIPTION		INC	
FIG	ITEM	SMR	STOCK	PART			IN	
NO	NO	CODE	NUMBER	NUMBER	FSCM	USABLE ON CODE	U/M	UNIT

GROUP 03 ANTENNA AS-1484/ARC-51X

10	1	PAOZZ	5935-00-928-3127	UG21E/U	80058	CONNECTOR, PLUG, ELEC	EA	1
----	---	-------	------------------	---------	-------	-----------------------	----	---

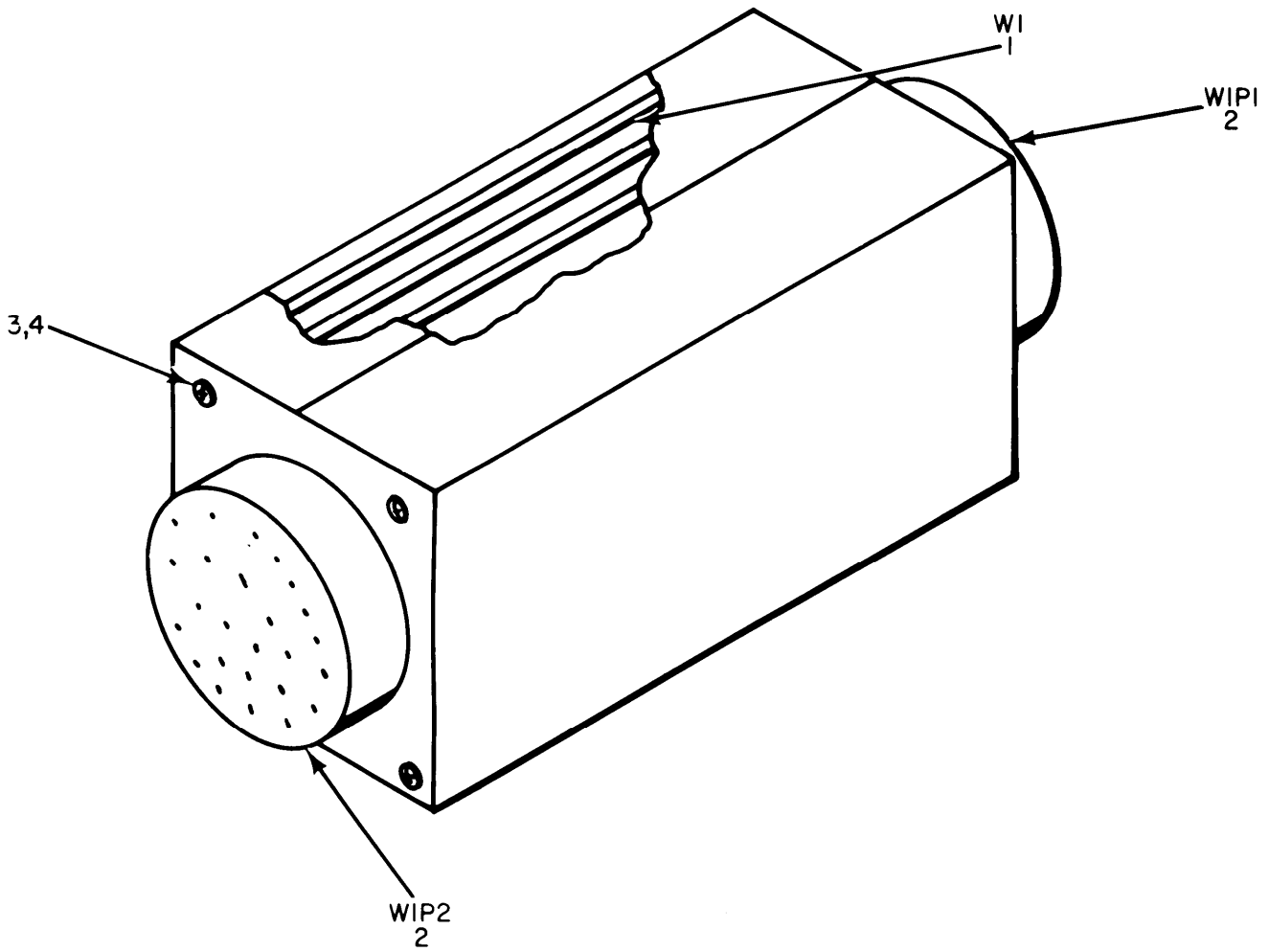

NOTE : FOR COMPLETE REFERENCE DESIGNATION PREFIX WITH A2.

EL4HK032.

Figure 11. Adapter, Connector U-335/ARC-51X.

SECTION II

(1)	(2)	(3)	(4)	(5)	(6)	(7)	(8)	
ILLUSTRATION							QTY	
(A)	(B)	NATIONAL			DESCRIPTION		INC	
FIG	ITEM	SMR	STOCK	PART			IN	
NO	NO	CODE	NUMBER	NUMBER	FSCM	USABLE ON CODE	U/M	UNIT
GROUP 04 ADAPTER,CONNECTOR U-335/ARC-51X								
11	1	XDOOO		761-7020-001	13499	WIRING HARNESS	EA	1
11	2	PAOZZ	5935-00-823-0212	MS3112E16-26PW	96906	CONNECTOR,RECEPTACL	EA	2
11	3	PAOZZ	5305-00-054-5647	MS51957-13	96906	SCREW,MACHINE	EA	8
11	4	PAOZZ	5310-00-058-2949	310-0278-000	70318	WASHER,LOCK	EA	8

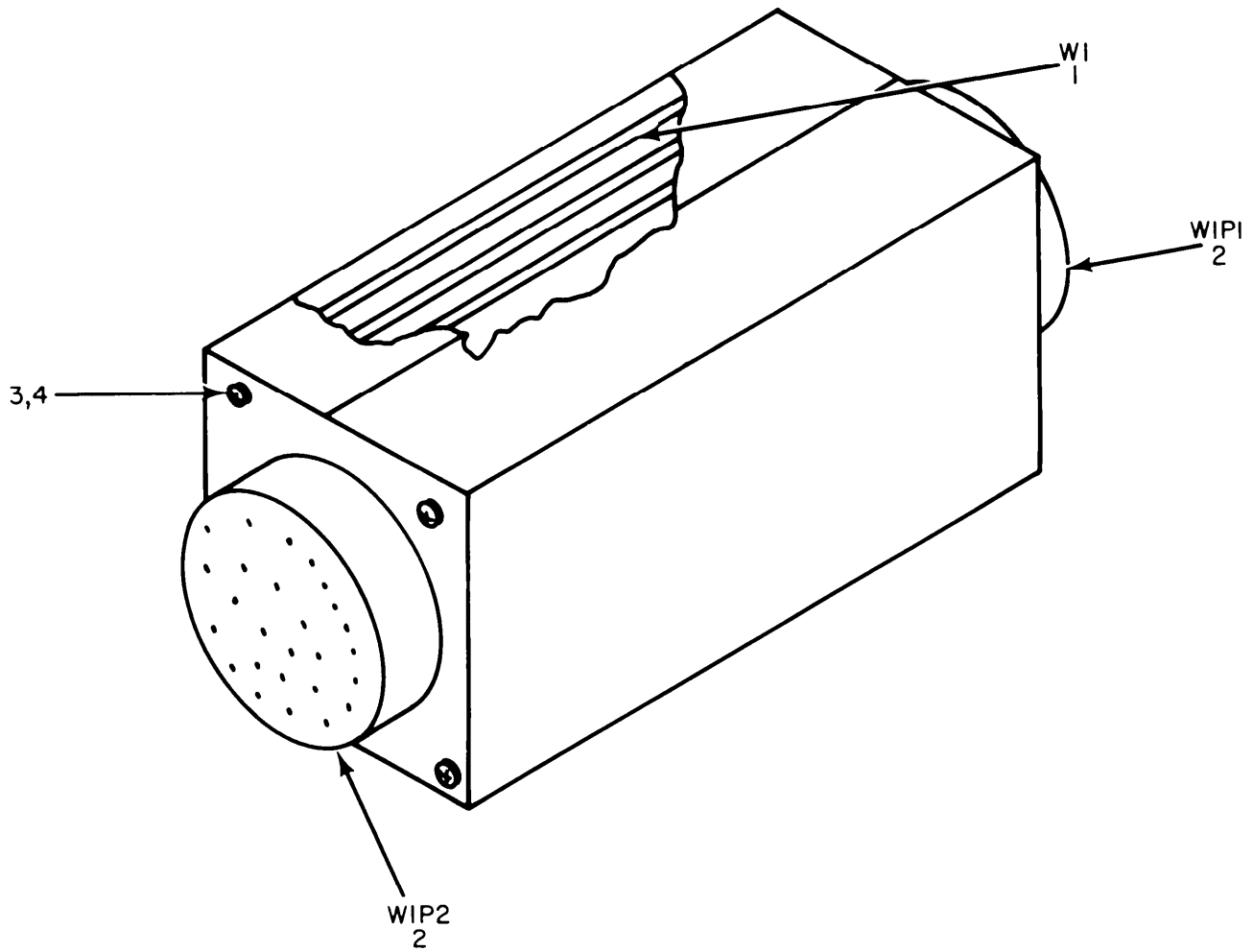

NOTE: FOR COMPLETE REFERENCE DESIGNATION PREFIX WITH A3.

EL4HK033

Figure 12. Adapter, Connector U-334/ARC-51X.

SECTION II

(1)	(2)	(3)	(4)	(5)	(6)	(7)	(8)
ILLUSTRATION							
(A)	(B)	NATIONAL		DESCRIPTION		QTY	
FIG	ITEM	SMR	STOCK	PART		INC	IN
NO	NO	CODE	NUMBER	NUMBER	FSCM	USABLE ON CODE	U/M UNIT
GROUP 05 ADAPTER,CONNECTOR U-334/ARC-51X							
12	1	PAOOO		761-7019-001	13499	WIRING HARNESS	EA 1
12	2	PAOZZ	5935-00-835-3031	MS3112E16-26P	96906	CONNECTOR,RECEPTACL	EA 2
12	3	PAOZZ	5305-00-054-5647	MS51957-13	96906	SCREW,MACHINE	EA 8
12	4	PAOZZ	5310-00-058-2949	310-0278-000	70318	WASHER,LOCK	EA 8

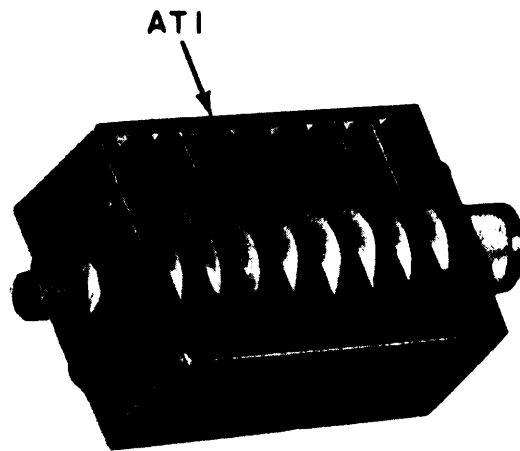

NOTE FOR COMPLETE REFERENCE
DESIGNATION PREFIX WITH ALL

EL4HK034

Figure 13. Dummy Load, Electrical DA-397/ARC-51X.

SECTION II

(1)	(2)	(3)	(4)	(5)	(6)	(7)	(8)	
ILLUSTRATION							QTY	
(A)	(B)	NATIONAL			DESCRIPTION		INC	
FIG	ITEM	SMR	STOCK	PART			IN	
NO	NO	CODE	NUMBER	NUMBER	FSCM	USABLE ON CODE	U/M	UNIT

GROUP 06 DUMMY LOAD,ELECTRICAL

DA-397/ARC-51X

13	1	PAOZZ	6625-00-738-5991	713-0055-010	13499	DUMMY LOAD,ELEC	EA	1
----	---	-------	------------------	--------------	-------	-----------------	----	---

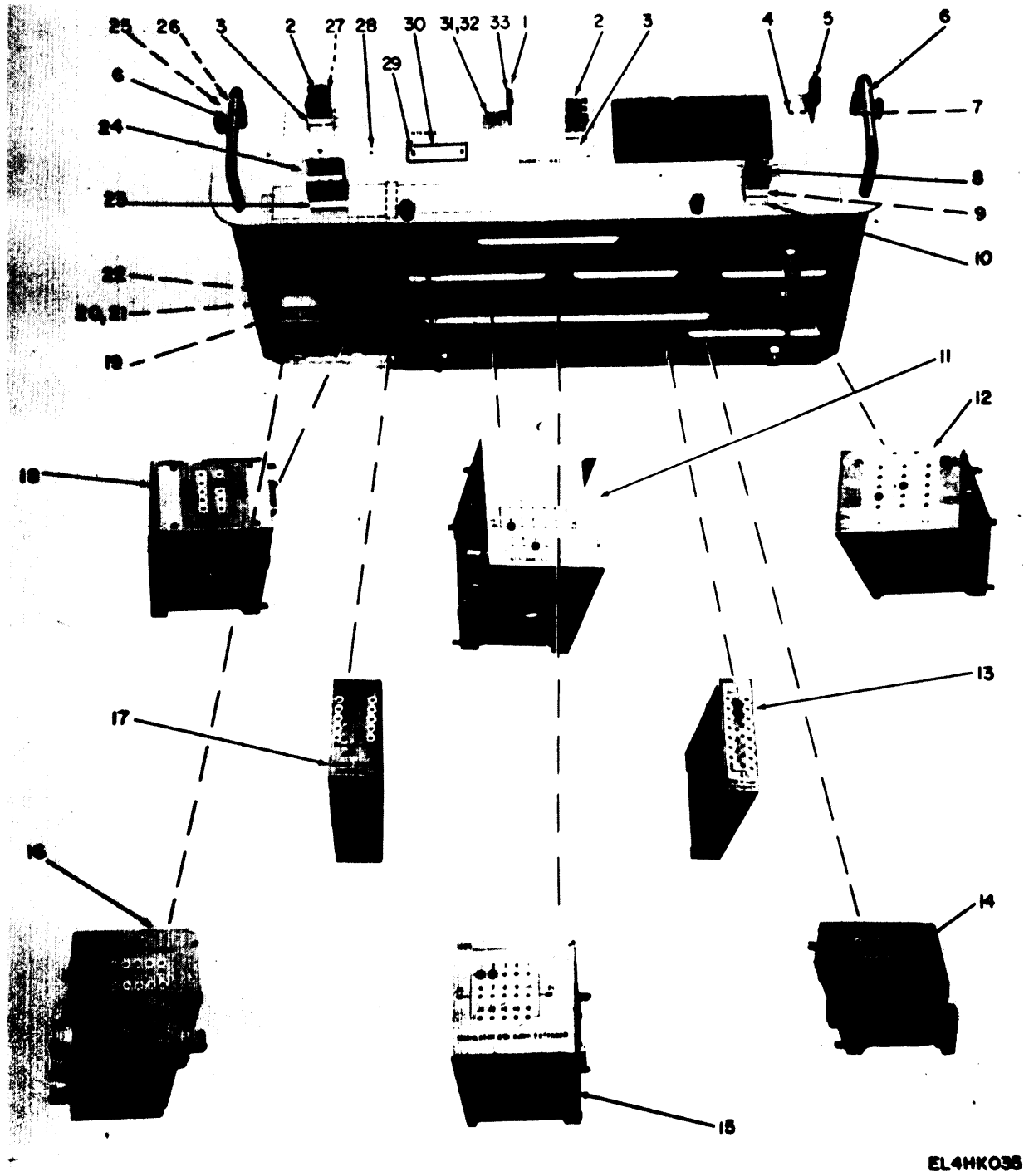

EL4HK036

Figure 14. Mounting Tray, Module Extender MT-3372/ARC-51X.

(1) ILLUSTRATION (A) FIG NO	(2) ITEM (B) NO	(3) SMR CODE	(4) NATIONAL STOCK NUMBER	(5) PART NUMBER	(6) FSCM	(7) DESCRIPTION	(8) QTY INC IN UNIT
GROUP 07 MOUNTING TRAY,MODULE EXTENDER							
MT-3372/ARC-51X							
14	1	XDOZZ		756-9024-001	13499	BRACKET, ANTENNA	EA 1
14	2	PAOZZ	5340-00-946-9442	6018-124CN	91506	CLIP, SPRING TENSION	EA 1
14	3	XDOZZ		761-7026-001	13499	SPACER, PLATE	EA 1
14	4	PAOZZ	5305-00-763-7822	MS51959-14	96906	SCREW, MACHINE	EA 13
14	5	XDOZZ		761-7025-001	13499	BRACKET, FXTR MI USED ONLY ON MK731ARC51X	EA 1
14	6	XDOZZ		NP9	08730	HANDLE, BOW	EA 2
14	7	PAOZZ	5305-00-071-1321	MS51960-64	96906	SCREW, MACHINE	EA 4
14	8	PAOZZ	5340-00-930-0107	6019-41CN	91506	CLIP, SPRING TENSION	EA 1
14	9	PAOZZ	5305-00-054-5648	MS51957-14	96906	SCREW, MACHINE	EA 1
14	10	XDOZZ		756-9021-001	13499	SPACER, PLATE	EA 1
14	11	PAOOO	6625-00-738-5982	MX4911ARC51X	80058	ADAPTER, TEST	EA 1
14	12	PAOOO	6625-00-738-5980	MX4909ARC51X	80058	ADAPTER, TEST	EA 1
14	13	PAOOO	6625-00-738-5979	MX4908ARC51X	80058	ADAPTER, TEST	EA 1
14	14	PAOOO	6625-00-738-5977	MX4906ARC51X	80058	ADAPTER, TEST	EA 1
14	15	PAOOO	6625-00-738-5975	MX4913ARC51X	80058	ADAPTER, TEST	EA 1
14	16	PAOOO	6625-00-738-5978	MX4907ARC51X	80058	EXTENDER, MODULE	EX Q/
14	17	PAOOO	6625-00-738-5983	MX4912ARC51X	80058	ADAPTER, TEST	EA 1
14	18	PAOOO	6625-00-738-5981	MX4910ARC51X	80058	EXTENDER, MODULE	EA 1
14	19	XDOZZ		756-9032-001	13499	BRACKET, SPARE P	EA 1
14	20	PAOZZ	5310-00-208-3786	P313-0132-00	77250	NUT, PLAIN, HEXAGON	EA 12
14	21	PAOZZ	5305-00-054-5653	MS51957-19	96906	SCREW, MACHINE	EA 4
14	22	XDOZZ		541-5987-002	13499	SPACER, SLEEVE	EA 4
14	23	XDOZZ		756-9020-001	13499	SPACER, PLATE	EA 1
14	24	PAOZZ	5340-00-930-0835	6020-11CN	91506	CLIP, SPRING TENSION	EA 1
14	25	PAOZZ	5340-00-722-8713	540-9168-003	13499	POST, ELECTRICAL-MEO	EA 2
14	26	PAOZZ	5305-00-777-6039	MS51959-12	96906	SCREW, MACHINE	EA 4
14	27	PAOZZ	5305-00-054-5650	MS51957-16	96906	SCREW, MACHINE	EA 2
14	28	PAOZZ	5305-00-054-5649	MS51957-15	96906	SCREW, MACHINE	EA 3
14	29	PAOZZ	5305-00-054-5635	MS51957-1	96906	SCREW, MACHINE	EA 2
14	30	XDOZZ		767-0764-008	13499	PLATE, IDENT	EA 1
14	31	PAOZZ	5305-00-054-5646	MS51957-12	96906	SCREW, MACHINE	EA 2
14	32	PAOZZ	5310-00-933-8118	MS35338-135	96906	WASHER, LOCK	EA 14
14	33	PAOZZ	5325-00-174-5317	MS35489-4	96906	GROMMET, RUBBER	EA 1

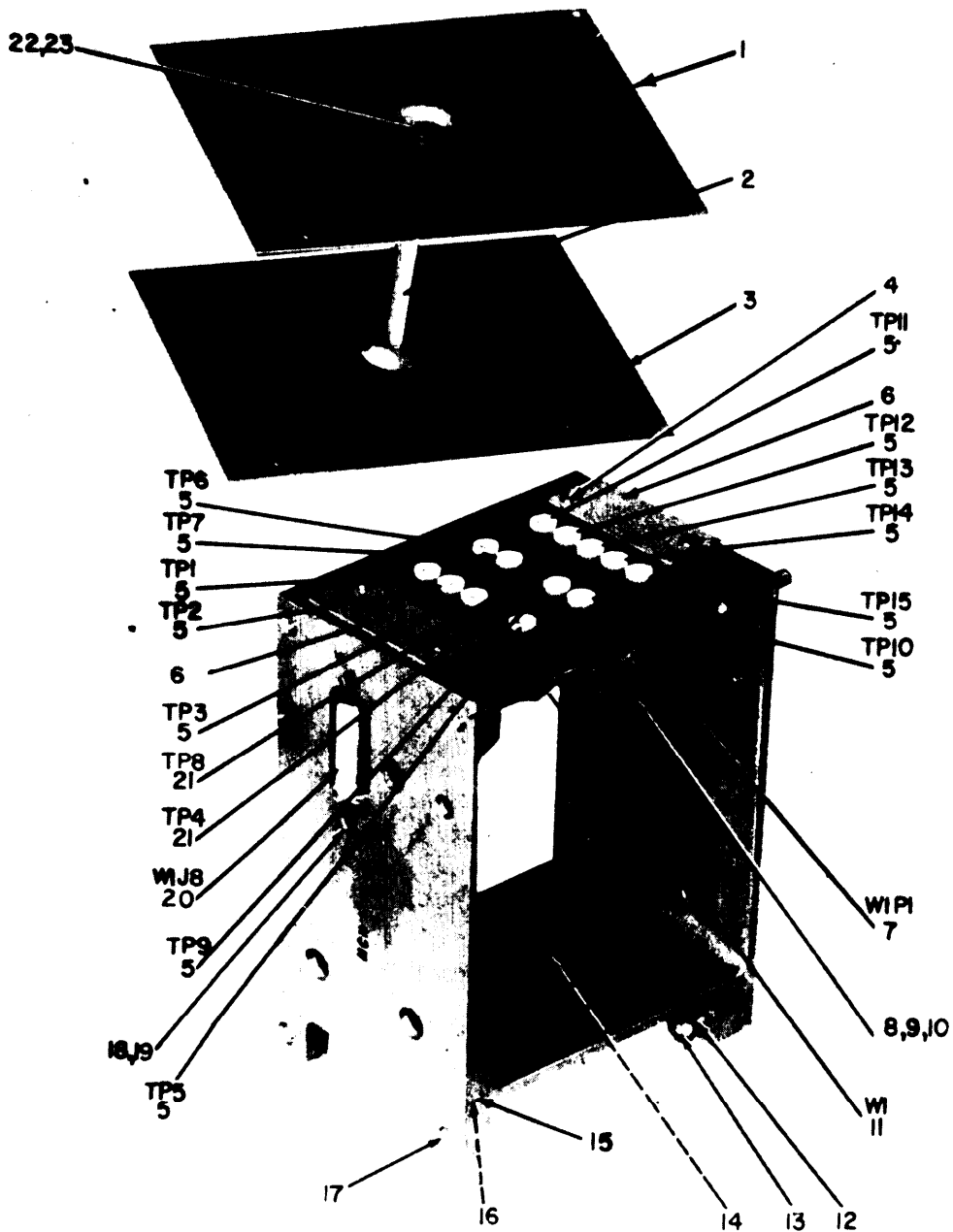

NOTE FOR COMPLETE REFERENCE DESIGNATION
 PREFIX WITH MP8

EL4HK036

Figure 15. Extender, Module MX-4913/ARC-51X.

SECTION II

(1) ILLUSTRATION (A) FIG NO	(2) (B) ITEM NO	(3) SMR CODE	(4) NATIONAL STOCK NUMBER	(5) PART NUMBER	(6) FSCM	(7) DESCRIPTION USABLE ON CODE	(8) QTY INC IN UNIT
GROUP 0701 EXTENDER,MODULE MX-4913/ARC-51X							
15	1	XDOZZ		756-8952-002	13499	COVER,MDL EXTEN	EX 1
15	2	XDOZZ		756-8969-001	13499	POST,ELMCH	EA 1
15	3	XDOZZ		756-8952-001	13499	COVER,MDL EXTEN	EA 1
15	4	PAOZZ	5305-00-054-5635	MS51957-1	96906	SCREW,MACHINE	EA 6
15	5	PAOZZ	5935-00-954-4470	SKT41WHITE	98291	JACK,TIP	EA 13
15	6	XDOZZ		756-8970-001	13499	PLATE,ACCESS CO	EA 2
15	7	PAOZZ	5935-00-057-2690	DA15P	71468	CONNECTOR,RECEPTACL	EA 1
15	8	PAOZZ	5305-00-763-3356	MS51959-5	96906	SCREW,MACHINE	EA 2
15	9	PAOZZ	5310-00-928-2690	310-0070-000	79807	WASHER,LOCK	EA 4
15	10	PAOZZ	5310-00-938-2013	MS35649-24	96906	NUT,PLAIN,HEXAGON	EA 4
15	11	XDOOO		761-7018-001	13499	WIRING HARNESS	EA 1
15	12	PAOZZ	5365-00-695-2558	340-0642-00	91314	RING,RETAINING	EA 4
15	13	PAOZZ	5305-00-909-1949	756-8924-001	13499	SCREW,CAP, SOCKET HE	EA 4
15	14	XDOZZ		767-0747-010	13499	PLATE,IDENT	EA 1
15	15	XDOZZ		756-8927-002	13499	PIN,LOCATING	EA 2
15	16	PAOZZ	5315-00-291-5471	MS16562-189	96906	PIN,SPRING	EA 4
15	17	PAOZZ	5340-00-479-9197	MS122119	96906	INSERT, SCREW THREAD	EA 4
15	18	PAOZZ	5310-00-907-0959	310-6320-000	79807	WASHER,FLAT	EA 2
15	19	PAOZZ	5305-00-727-8833	MS51959-3	96906	SCREW,MACHINE	EA 2
15	20	PAOZZ	5935-00-993-2181	DAF15S	71468	CONNECTOR,RECEPTACL	EA 1
15	21	PAOZZ	5935-00-061-1363	SKT41RED	98291	JACK,TIP	EA 2
15	22	PAOZZ	5305-00-054-6651	MS51957-27	96906	SCREW,MACHINE	EA 2
15	23	PAOZZ	5310-00-929-6395	310-0071-000	79807	WASHER,LOCK	EA 2

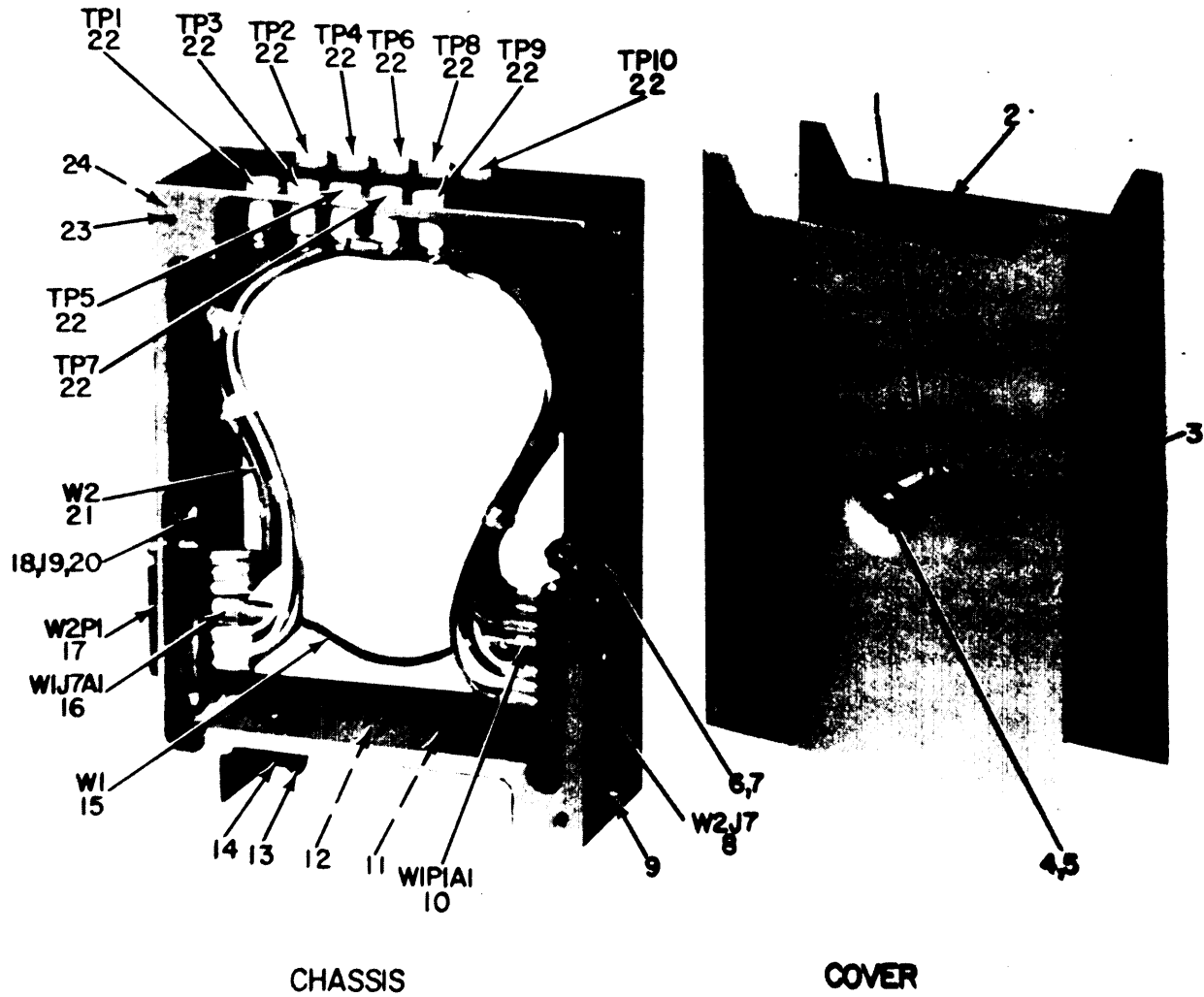

Figure 16. Extender, Module MX-4912/ARC-51X.

EL4HK037

SECTION II

(1) ILLUSTRATION (A) FIG NO	(2) (B) ITEM NO	(3) SMR CODE	(4) NATIONAL STOCK NUMBER	(5) PART NUMBER	(6) DESCRIPTION FSCM	(7) USABLE ON CODE	(8) QTY INC IN UNIT
GROUP 0702 EXTENDER,MODULE MX-4912/ACR-51X							
16	1	XDOZZ		756-8978-001	13499 POST,ELMCH	EA	1
16	2	XDOZZ		756-8985-001	13499 COVER,MDL EXTEN	EX	1
16	3	XDOZZ		756-8982-002	13499 COVER,MDL EXTEN	EA	1
16	4	PAOZZ	5305-00-054-6651	MS51957-27	96906 SCREW,MACHINE	EA	2
16	5	PAOZZ	5310-00-929-6395	310-0071-000	79807 WASHER,LOCK	EA	2
16	6	PAOZZ	5305-00-763-3356	MS51959-5	96906 SCREW,MACHINE	EA	2
16	7	PAOZZ	5310-00-928-2690	310-0070-000	79807 WASHER,LOCK	EA	4
16	8	PAOZZ	5935-00-059-2640	DAMF11W1S	71468 CONNECTOR,RECEPTACL	EA	1
16	9	PAOZZ	5340-00-479-9197	MS122119	96906 INSERT,SCREW THREAD	EA	2
16	10	PAOZZ	5935-00-885-6505	DM53740-5000	71468 CONNECTOR,PLUG,ELEC	EA	1
16	11	PAOZZ	5305-00-054-5635	MS51957-1	96906 SCREW,MACHINE	EA	2
16	12	XDOZZ		767-0748-010	13499 PLATE,IDENT	EA	1
16	13	PAOZZ	5305-00-909-1949	756-8924-001	13499 SCREW,CAP,SOCKET, HE	EA	2
16	14	PAOZZ	5365-00-695-2558	340-0642-00	91314 RING,RETAINING	EA	2
16	15	XDOOO		761-7003-002	13499 CABLE ASSEMBLY	EA	1
16	16	PAOZZ	5935-00-080-0268	DM53742-5000	71468 CONNECTOR,PLUG,ELEC	EA	1
16	17	PAOZZ	5935-00-901-5850	DAM11W1P	71468 CONNECTOR,RECEPTACL	EA	1
16	18	PAOZZ	5310-00-938-2013	MS35649-24	96906 NUT,PLAIN,HEXAGON	EA	4
16	19	PAOZZ	5305-00-727-8833	MS51959-3	96906 SCREW,MACHINE	EA	2
16	20	PAOZZ	5310-00-907-0959	310-6320-000	79807 WASHER,FLAT	EA	2
16	21	XDOOO		761-7016-001	13499 WIRING HARNESS	EA	1
16	22	PAOZZ	5935-00-954-4470	SKT41WHITE	98291 JACK,TIP	EA	10
16	23	XDOZZ		756-8927-002	13499 PIN,LOCATING	EA	2
16	24	PAOZZ	5315-00-291-5471	MS16562-189	96906 PIN,SPRING	EA	4

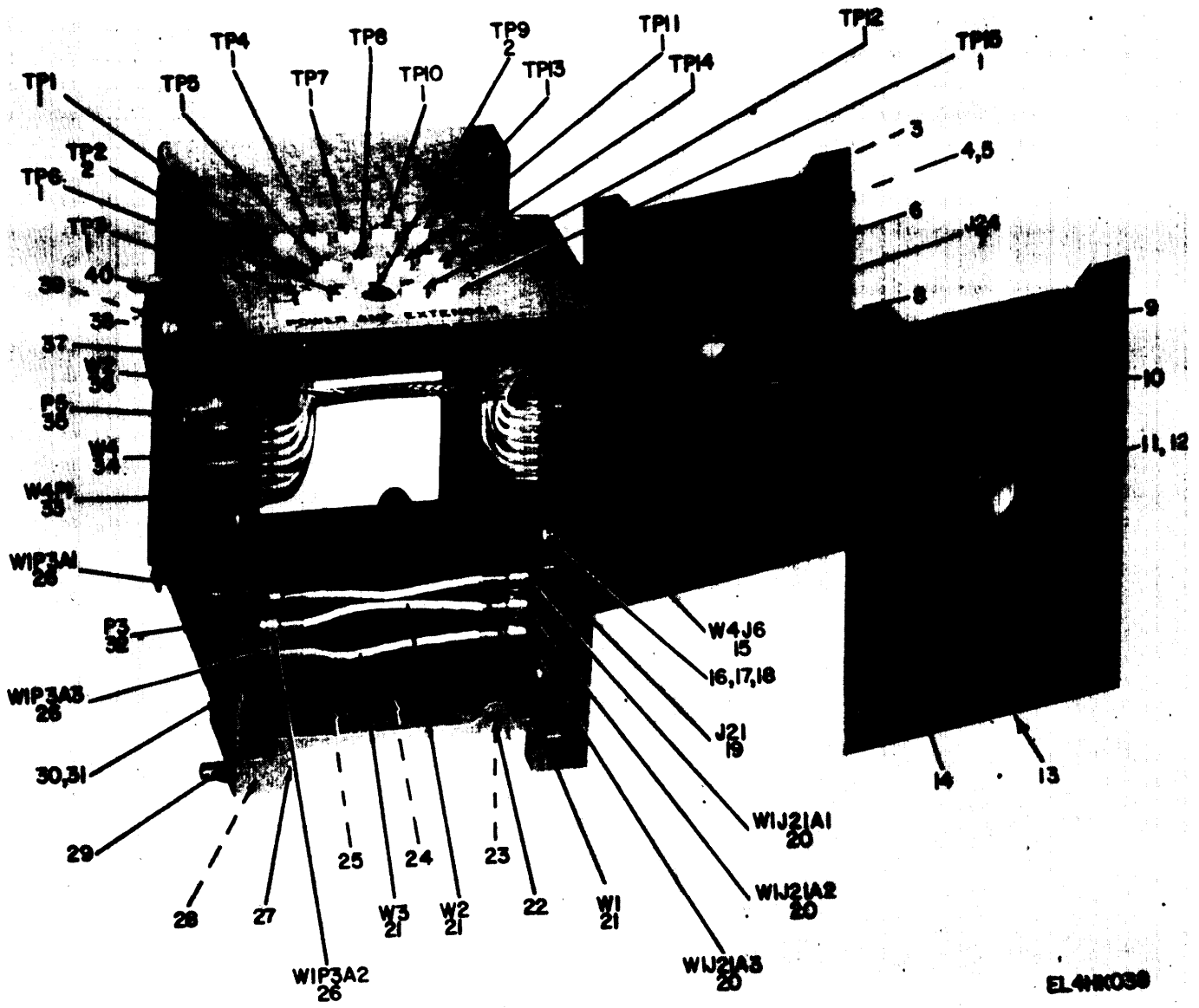

Figure 17. Extender, Module MX-4911/ARC-51X.

SECTION II

(1) ILLUSTRATION (A) FIG NO	(2) (B) ITEM NO	(3) SMR CODE	(4) NATIONAL STOCK NUMBER	(5) PART NUMBER	(6) DESCRIPTION FSCM	(7) USABLE ON CODE	(8) QTY INC IN UNIT
GROUP 0703 EXTENDER,MODULE MX-4911/ARC-51X							
17	1	PAOZZ	5935-00-954-4470	SKT41WHITE	98291 JACK, TIP	EA	13
17	2	PAOZZ	5935-00-061-1363	SKT41RED	98291 JACK, TIP	EA	2
17	3	XDOZZ		756-8922-001	13499 PLATE, RING, SFT	EA	1
17	4	PAOZZ	5305-00-054-5646	MS51957-12	96906 SCREW, MACHINE	EA	4
17	5	PAOZZ	5310-00-058-2949	310-0278-000	70318 WASHER, LOCK	EA	4
17	6	XDOZZ		756-8942-001	13499 COVER, MDL EXTEN	EA	1
17	7	PAOZZ	5935-00-881-9480	51-258	98278 CONNECTOR, RECEPTCL	EA	1
17	8	XDOZZ		756-8936-001	13499 BUSHING, MACHINE	EA	1
17	9	XDOZZ		53-315	98278 CONNECTOR, GRD, S	EA	2
17	10	XDOZZ		756-8937-001	13499 WASHER, FLAT	EA	1
17	11	PAOZZ	5305-00-054-6651	MS51957-27	96906 SCREW, MACHINE	EA	2
17	12	PAOZZ	5310-00-929-6395	310-0071-000	79807 WASHER, LOCK	EA	2
17	13	XDOZZ		756-8942-002	13499 COVER, MDL EXTEN	EA	1
17	14	XDOZZ		756-8928-001	13499 POST, ELMCH	EA	1
17	15	PAOZZ	5935-00-993-2181	DAF15S	71468 CONNECTOR, RECEPTCL	EA	1
17	16	PAOZZ	5310-00-938-2013	MS35649-24	96906 NUT, PLAIN, HEXAGON	EA	8
17	17	PAOZZ	5305-00-763-3356	MS51959-5	96906 SCREW, MACHINE	EA	4
17	18	XDOZZ		310000070000	79807 WASHER, LOCK	EA	8
17	19	PAOZZ	5935-00-089-6921	DAMF3W3S	71468 CONNECTOR, RECEPTCL	EA	1
17	20	PAOZZ	5935-00-080-0268	DM53742-5000	71468 CONNECTOR, PLUG, ELEC	EA	3
17	21	XDOOO		761-7003-002	13499 CABLE ASSEMBLY	EA	3
17	22	XDOZZ		756-8927-001	13499 PIN, LOCATING	EA	2
17	23	PAOZZ	5315-00-291-5471	MS16562-189	96906 PIN, SPRING	EA	4
17	24	XDOZZ		767-0758-010	13499 PLATE, IDENT	EA	1
17	25	PAOZZ	5305-00-054-5635	MS51957-1	96906 SCREW, MACHINE	EA	2
17	26	PAOZZ	5935-00-885-6505	DM53740-5000	71468 CONNECTOR, PLUG, ELEC	EA	3
17	27	PAOZZ	5305-00-909-1949	756-8924-001	13499 SCREW, CAP, SOCKET HE	EA	4
17	28	PAOZZ	5340-00-479-9197	MS122119	96906 INSERT, SCREW THREAD	EA	4
17	29	PAOZZ	5365-00-695-2558	340-0642-00	91314 RING, RETAINING	EA	4
17	30	PAOZZ	5305-00-727-8833	MS51959-3	96906 SCREW, MACHINE	EA	4
17	31	PAOZZ	5310-00-907-0959	310-6320-000	79807 WASHER, FLAT	EA	4
17	32	PAOZZ	5935-00-089-6505	DAM3W3P	71468 CONNECTOR BODY, RECE	EA	1
17	33	PAOZZ	5935-00-057-2690	DA15P	71468 CONNECTOR, RECEPTCL	EA	1
17	34	XDOOO		761-7014-001	13499 WIRING HARNESS	EA	1
17	35	PAOZZ	5935-00-088-9619	052-0512	98278 CONNECTOR, RECEPTCL	EA	1
17	36	PAOZZ	6145-00-080-6517	RG303U	81349 CABLE, RF	FT	1
17	37	PAOZZ	6625-00-058-3841	761-7006-002	13499 SHAFT AND PIN ASSEM	EA	1
17	38	PAOZZ	5821-00-021-4832	549-3856-002	13499 INSERT, FLEXIBLE COU	EA	1
17	39	PAOZZ	6625-00-058-3811	756-8926-001	13499 RETAINER, COUPLING	EA	1

SECTION II

(1)	(2)	(3)	(4)	(5)	(6)	(7)	(8)	
ILLUSTRATION							QTY	
(A)	(B)		NATIONAL		DESCRIPTION		INC	
FIG	ITEM	SMR	STOCK	PART			IN	
NO	NO	CODE	NUMBER	NUMBER	FSCM	USABLE ON CODE	U/M	UNIT
17	40	PAOZZ	5330-00-824-9130	213-141216-00-2303	78189	PACKING PERFORMED	EA	1

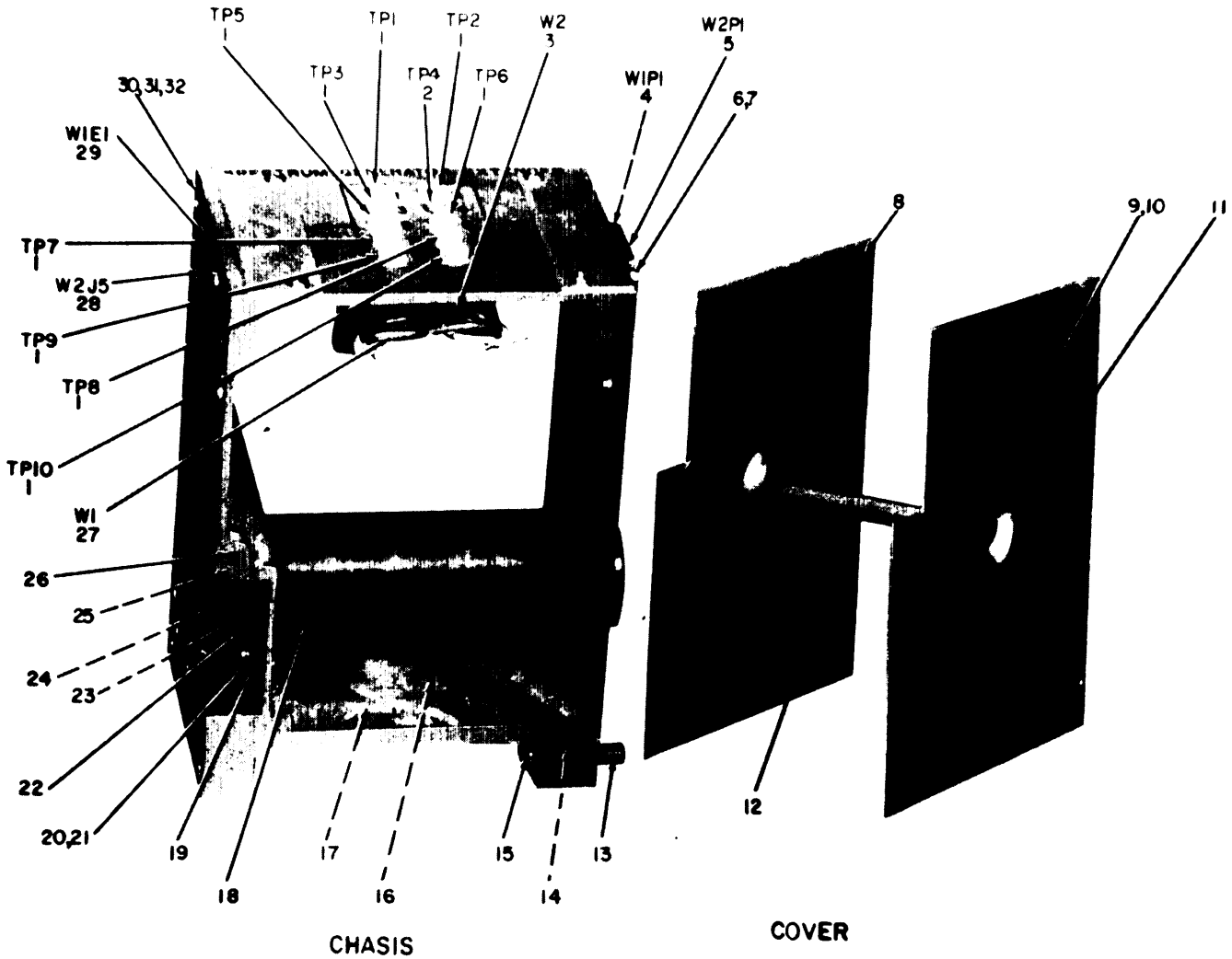

NOTE: FOR COMPLETE REFERENCE DESIGNATION PREFIX WITH MP5

EL4HK039

Figure 18. Extender, Module MX-4910/ARC-51X.

SECTION II

(1) ILLUSTRATION (A) FIG NO	(2) (B) ITEM NO	(3) SMR CODE	(4) NATIONAL STOCK NUMBER	(5) PART NUMBER	(6) DESCRIPTION FSCM	(7) USABLE ON CODE	(8) QTY INC IN UNIT
GROUP 0704 EXTENDER,MODULE MX-4910/ARC-51X							
18	1	PAOZZ	5935-00-954-4470	SKT41WHITE	98291 JACK, TIP	EA	9
18	2	PAOZZ	5935-00-061-1363	SKT41RED	98291 JACK, TIP	EA	1
18	3	XDOOO		761-7012-001	13499 WIRING HARNESS	EA	1
18	4	PAOZZ	5935-00-885-6505	DM53740-5000	71468 CONNECTOR, PLUG, ELEC	EA	1
18	5	PAOZZ	5935-00-901-5850	DAM11W1P	71468 CONNECTOR, RECEPTACL	EA	1
18	6	PAOZZ	5310-00-938-2013	MS35649-24	96906 NUT, PLAIN, HEXAGON	EA	4
18	7	PAOZZ	5305-00-727-8833	MS51959-3	96906 SCREW, MACHINE	EA	2
18	8	XDOZZ		756-8916-001	13499 COVER, MDL EXTEN	EA	1
18	9	PAOZZ	5305-00-054-6651	MS51957-27	96906 SCREW, MACHINE	EA	2
18	10	PAOZZ	5310-00-929-6395	310-0071-000	79807 WASHER, LOCK	EA	2
18	11	XDOZZ		756-8916-002	13499 COVER, MDL EXTEN	EA	1
18	12	XDOZZ		756-8911-001	13499 POST, ELECTRICAL-MEO	EA	1
18	13	PAOZZ	5365-00-695-2558	340-0642-00	91314 RING, RETAINING	EA	3
18	14	PAOZZ	5340-00-479-9197	MS122119	96906 INSERT, SCREW THREAD	EA	3
18	15	PAOZZ	5305-00-909-1949	756-8924-001	13499 SCREW, CAP, SOCKET HE	EA	3
18	16	XDOZZ		767-0759-010	13499 PLATE, IDENT	EA	1
18	17	PAOZZ	5305-00-054-5635	MS51957-1	96906 SCREW, MACHINE	EA	6
18	18	PAOZZ	6625-00-058-3841	761-7006-002	13499 SHAFT AND PIN ASSEM	EA	1
18	19	XDOZZ		756-8922-001	13499 PLATE, RETAINING	EA	1
18	20	PAOZZ	5305-00-054-5646	MS51957-12	96906 SCREW, MACHINE	EA	4
18	21	PAOZZ	5310-00-058-2949	310-0278-000	70318 WASHER, LOCK	EA	4
18	22	PAOZZ	6625-00-058-3811	756-8926-001	13499 RETAINER, COUPLING	EA	1
18	23	PAOZZ	5821-00-021-4832	549-3856-002	13499 INSERT, FLEXIBLE COU	EA	1
18	24	PAOZZ	5330-00-824-9130	213-141216-00-2303	78189 PACKING PERFORMED	EA	1
18	25	PAOZZ	5315-00-291-5471	MS16562-189	96906 PIN, SPRING	EA	4
18	26	XDOZZ		756-8927-001	13499 PIN, LOCATING	EA	2
18	27	XDOOO		761-7003-002	13499 CABLE ASSEMBLY	EA	1
18	28	PAOZZ	5935-00-059-2640	DAMF11W1S	71468 CONNECTOR, RECEPTACL	EA	1
18	29	PAOZZ	5935-00-080-0268	DM53742-5000	71468 CONNECTOR, PLUG, ELEC	EA	1
18	30	PAOZZ	5305-00-763-3356	MS51959-5	96906 SCREW, MACHINE	EA	2
18	31	PAOZZ	5310-00-907-0959	310-6320-000	79807 WASHER, FLAT	EA	2
18	32	PAOZZ	5310-00-928-2690	310-0070-000	79807 WASHER, LOCK	EA	4

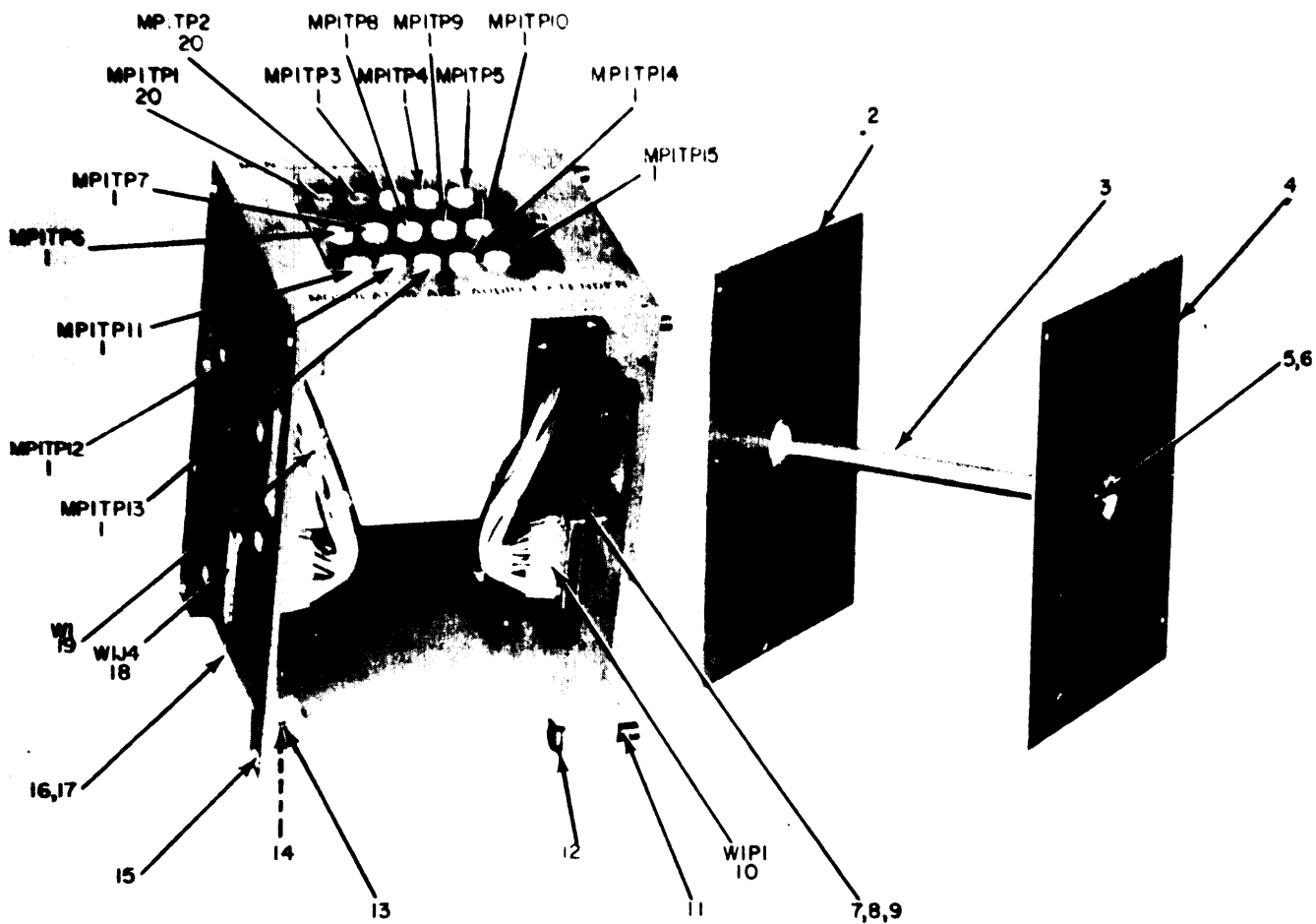

NOTE: FOR COMPLETE REFERENCE DESIGNATION PREFIX WITH MP4

EL4HK040

Figure 19. Extender, Module MX-4909/ARC-51X.

SECTION II

(1) ILLUSTRATION (A) FIG NO	(2) (B) ITEM NO	(3) NATIONAL STOCK NUMBER	(4) PART NUMBER	(5) FSCM	(6) DESCRIPTION	(7) USABLE ON CODE	(8) QTY INC IN UNIT
GROUP 0705 EXTENDER,MODULE MX-4909/ARC-51X							
19	1	PAOZZ 5935-00-954-4470	SKT41WHITE	98291	JACK, TIP	EA	13
19	2	XDOZZ	756-8952-001	13499	COVER,MDL EXTEN	EA	1
19	3	XDOZZ	756-8958-001	13499	POST,ELECTRICAL-MEO	EA	1
19	4	XDOZZ	756-8952-002	13499	COVER,MDL EXTEN	EA	1
19	5	PAOZZ 5305-00-054-6651	MS51957-27	96906	SCREW,MACHINE	EA	2
19	6	PAOZZ 5310-00-929-6395	310-0071-000	79807	WASHER, LOCK	EA	2
19	7	PAOZZ 5305-00-763-3356	MS51959-5	96906	SCREW,MACHINE	EA	2
19	8	PAOZZ 5310-00-907-0959	310-6320-000	79807	WASHER, FLAT	EA	2
19	9	PAOZZ 5310-00-928-2690	310-0070-000	79807	WASHER, LOCK	EA	2
19	10	PAOZZ 5935-00-057-2690	DA15P	71468	CONNECTOR,RECEPTACL	EA	1
19	11	PAOZZ 5365-00-695-2558	340-0642-00	91314	RING,RETAINING	EA	4
19	12	PAOZZ 5305-00-909-1949	756-8924-001	13499	SCREW,CAP, SOCKET HE	EA	4
19	13	XDOZZ	756-8927-002	13499	PIN,LOCATING	EA	2
19	14	PAOZZ 5315-00-291-5471	MS16562-189	96906	PIN,SPRING	EA	4
19	15	PAOZZ 5340-00-479-9197	MS122119	96906	INSERT,SCREW THREAD	EA	4
19	16	PAOZZ 5310-00-938-2013	MS35649-24	96906	NUT,PLAIN,HEXAGON	EA	4
19	17	PAOZZ 5305-00-727-8833	MS51959-3	96906	SCREW,MACHINE	EA	2
19	18	PAOZZ 5935-00-993-2181	DAF15S	71468	CONNECTOR,RECEPTACL	EA	1
19	19	XDOOO	761-7010-001	13499	WIRING HARNESS	EA	1
19	20	PAOZZ 5935-00-061-1363	SKT41RED	98291	JACK, TIP	EA	2

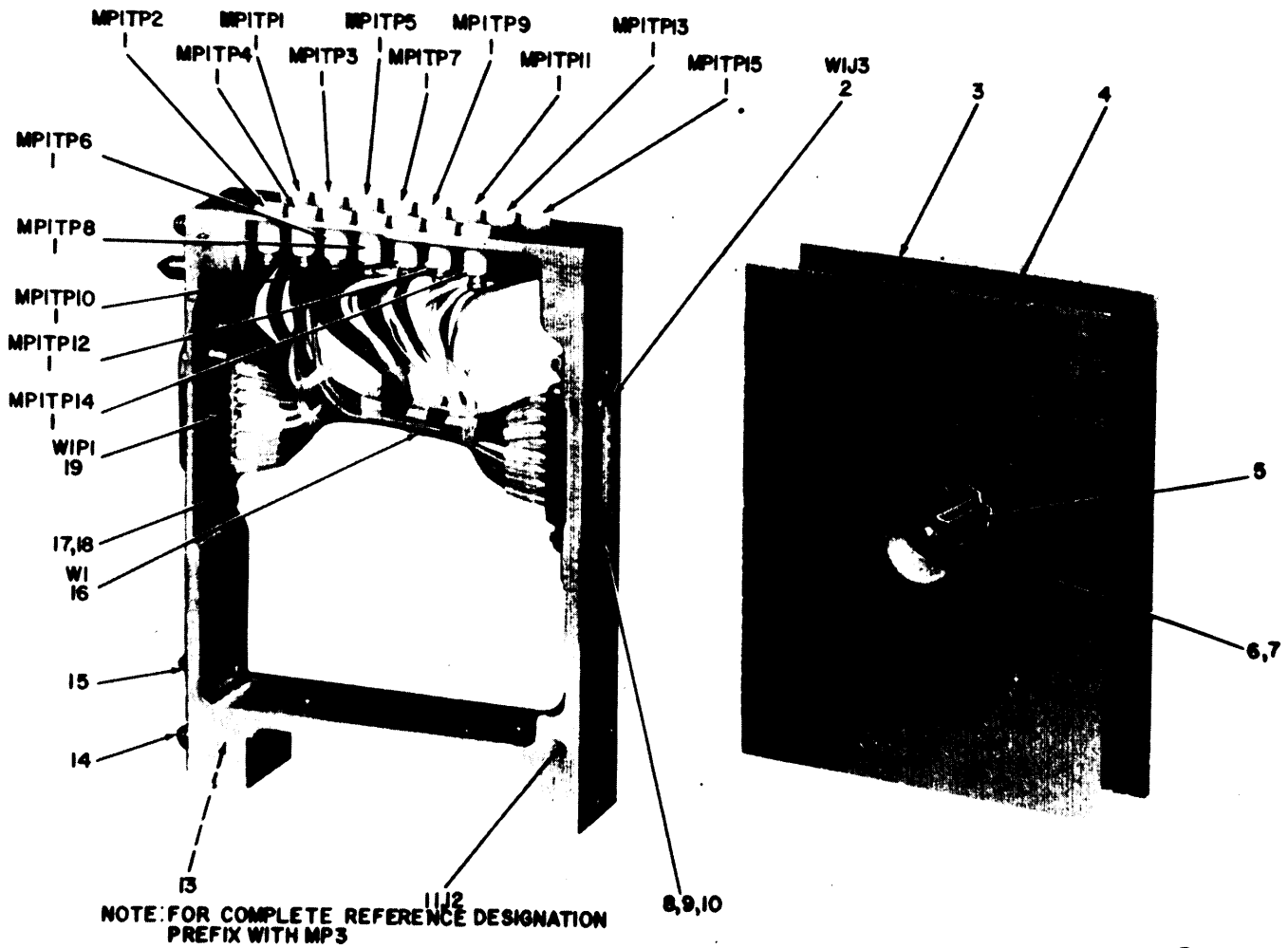
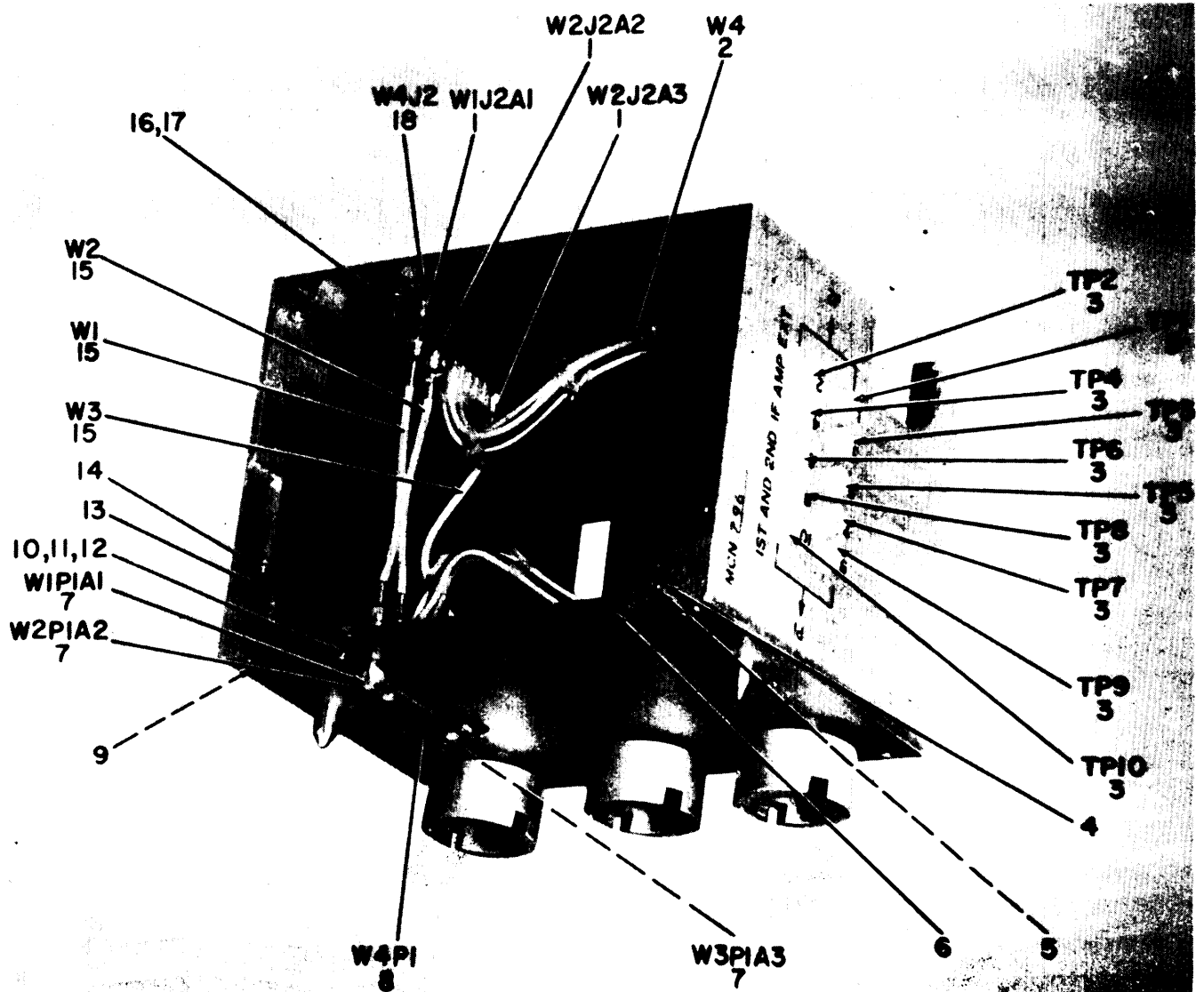

Figure 20. Extender, Module MX-4908/ARC-51X.

SECTION II

(1) ILLUSTRATION (A) FIG NO	(2) (B) ITEM NO	(3) SMR CODE	(4) NATIONAL STOCK NUMBER	(5) PART NUMBER	(6) FSCM	(7) DESCRIPTION USABLE ON CODE	(8) QTY INC IN UNIT
GROUP 0706 EXTENDER,MODULE MX-4908/ARC-51X							
20	1	PAOZZ	5935-00-954-4470	SKT41WHITE	98291	JACK,TIP	EA 15
20	2	PAOZZ	5935-00-993-2181	DAF15S	71468	CONNECTOR,RECEPTACL	EA 1
20	3	XDOZZ		756-8905-001	13499	COVER,MDL EXTEN	EA 1
20	4	XDOZZ		756-8905-002	13499	COVER,MDL EXTEN	EA 1
20	5	XDOZZ		756-8902-001	13499	POST,ELMCH	EA 1
20	6	PAOZZ	5305-00-054-6651	MS51957-27	96906	SCREW,MACHINE	EA 2
20	7	PAOZZ	5310-00-929-6395	310-0071-000	79807	WASHER,LOCK	EA 2
20	8	PAOZZ	5305-00-763-3356	MS51959-5	96906	SCREW,MACHINE	EA 2
20	9	PAOZZ	5310-00-907-0959	310-6320-000	79807	WASHER,FLAT	EA 2
20	10	PAOZZ	5310-00-928-2690	310-0070-000	79807	WASHER,LOCK	EA 4
20	11	XDOZZ		756-8927-002	13499	PIN,LOCATING	EA 2
20	12	PAOZZ	5315-00-291-5471	MS16562-189	96906	PIN,SPRING	EA 4
20	13	PAOZZ	5340-00-479-9197	MS122119	96906	INSERT,SCREW THREAD	EA 2
20	14	PAOZZ	5305-00-909-1949	756-8924-001	13499	SCREW,CAP, SOCKET HE	EA 1
20	15	PAOZZ	5365-00-695-2558	340-0642-00	91314	RING,RETAINING	EA 2
20	16	XDOOO		761-7008-001	13499	WIRING HARNESS	EA 1
20	17	PAOZZ	5310-00-938-2013	MS35649-24	96906	NUT,PLAIN,HEXAGON	EA 4
20	18	PAOZZ	5305-00-727-8833	MS51959-3	96906	SCREW,MACHINE	EA 2
20	19	PAOZZ	5935-00-057-2690	DA15P	71468	CONNECTOR,RECEPTACL	EA 1



TOP AND LEFT SIDE VIEW

**NOTE: FOR COMPLETE REFERENCE DESIGNATION
PREFIX WITH MP2.**

EL4HK042

Figure 21. Extender, Module MX-4907/ARC-51X (Sheet 1 of 2).

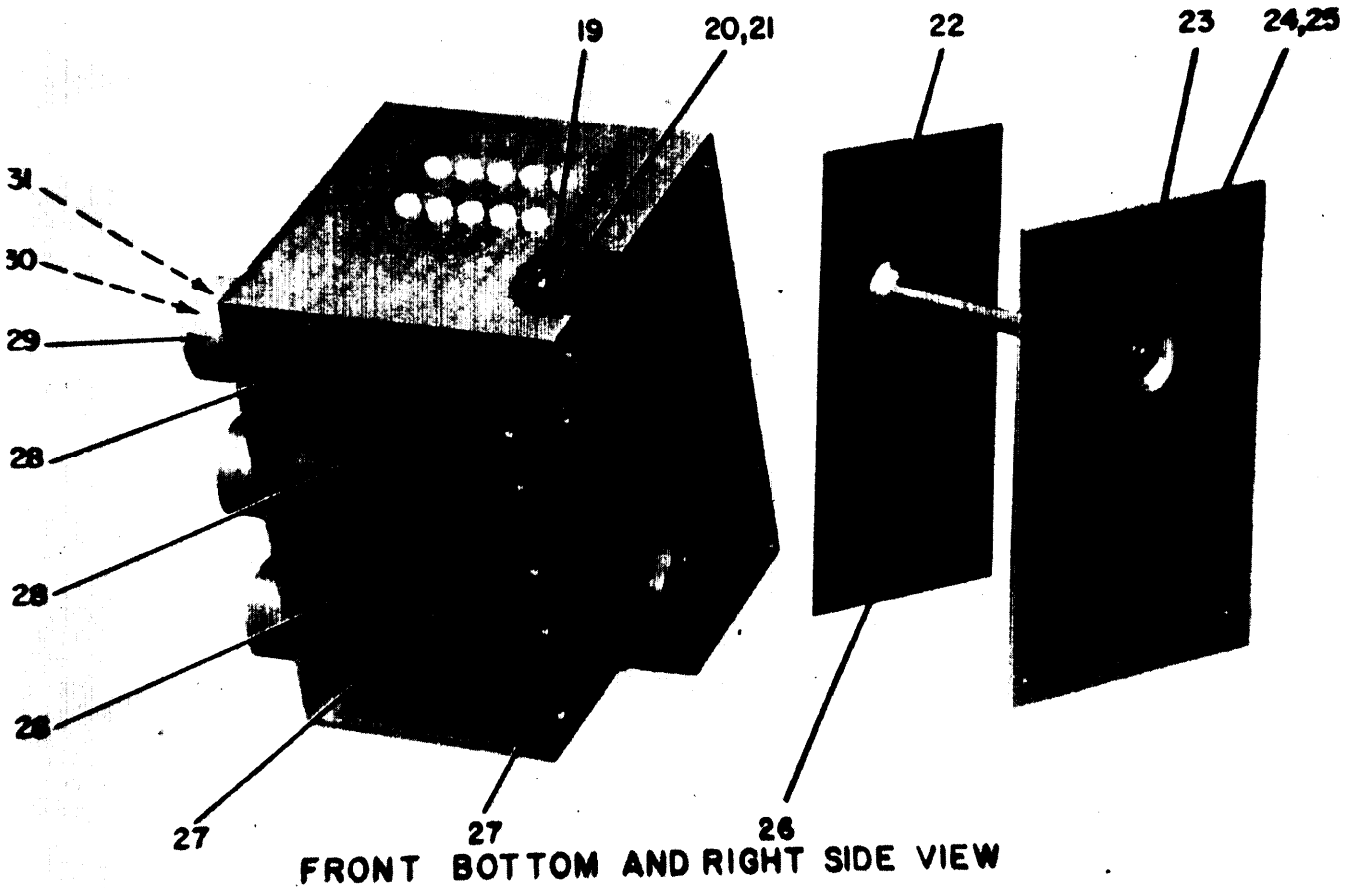
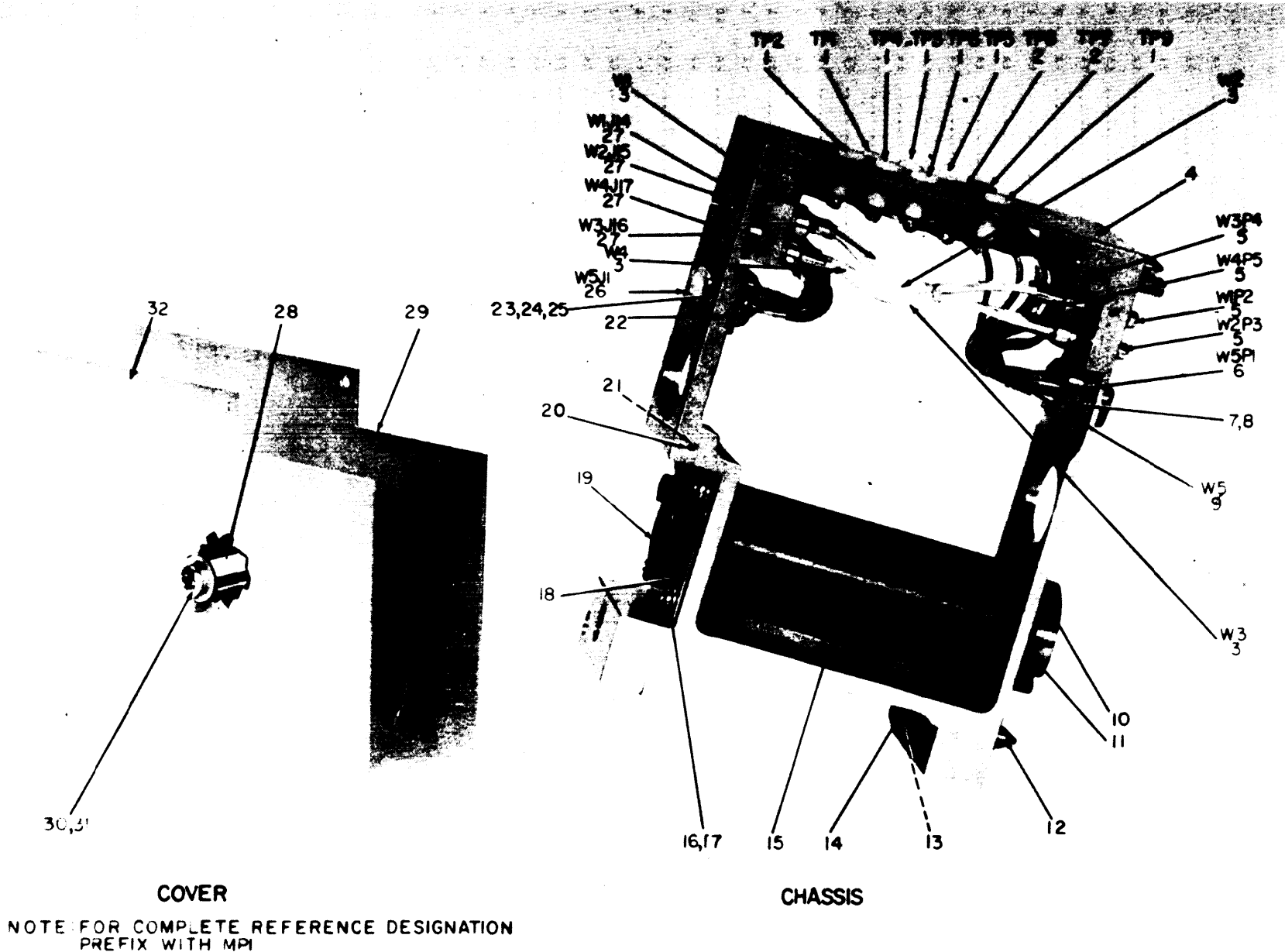

Figure 21. Extender, Module MX-4907/ARC-51X (Sheet 2 of 2).

SECTION II

(1) ILLUSTRATION (A) FIG NO	(2) ITEM (B) NO	(3) SMR CODE	(4) NATIONAL STOCK NUMBER	(5) PART NUMBER	(6) DESCRIPTION FSCM	(7) USABLE ON CODE	(8) QTY INC IN UNIT
GROUP 0707 EXTENDER,MODULE MX-4907/ARC-51X							
21	1	PAOZZ	5935-00-080-0268	DM53742-5000	71468 CONNECTOR,PLUG,ELEC	EA	3
21	2	XDOOO		761-7005-001	13499 WIRING HARNESS	EA	1
21	3	PAOZZ	5935-00-954-4470	SKT41WHITE	98291 JACK,TIP	EA	10
21	4	XDOZZ		756-8927-001	13499 PIN,LOCATING	EA	2
21	5	PAOZZ	5315-00-291-5471	MS16562-189	96906 PIN,SPRING	EA	4
21	6	XDOZZ		756-8967-001	13499 CHASSIS,MDL EXT	EA	1
21	7	PAOZZ	5935-00-885-6505	DM53740-5000	71468 CONNECTOR,PLUG,ELEC	EA	3
21	8	PAOZZ	5935-00-811-1382	DBM13W3P	71468 CONNECTOR,RECEPTACL	EA	1
21	9	PAOZZ	5340-00-479-9197	MS122119	96906 INSERT,SCREW THREAD	EA	3
21	10	PAOZZ	5305-00-763-3356	MS51959-5	96906 SCREW,MACHINE	EA	2
21	11	PAOZZ	5310-00-907-0959	310-6320-000	79807 WASHER,FLAT	EA	2
21	12	PAOZZ	5310-00-928-2690	310-0070-000	79807 WASHER,LOCK	EA	4
21	13	PAOZZ	5365-00-695-2558	340-0642-00	91314 RING,RETAINING	EA	3
21	14	PAOZZ	5305-00-909-1949	756-8924-001	13499 SCREW,CAP,SOCKET HE	EA	3
21	15	XDOOO		761-7003-001	13499 CABLE ASSEMBLY	EA	3
21	16	PAOZZ	5310-00-938-2013	MS35649-24	96906 NUT,PLAIN,HEXAGON	EA	4
21	17	PAOZZ	5305-00-727-8833	MS51959-3	96906 SCREW,MACHINE	EA	2
21	18	PAOZZ	5935-00-089-1165	DBMF13W3S	71468 CONNECTOR,RECEPTACL	EA	1
21	19	XDOZZ		756-8922-001	13499 PLATE,RING SFT	EA	1
21	20	PAOZZ	5305-00-054-5646	MS51957-12	96906 SCREW,MACHINE	EA	10
21	21	PAOZZ	5310-00-058-2949	310-0278-000	70318 WASHER,LOCK	EA	10
21	22	XDOZZ		756-8964-001	13499 COVER,MDL EXTEN	EA	1
21	23	XDOZZ		756-8963-001	13499 COVER,MDL EXTEN	EA	1
21	24	PAOZZ	5305-00-054-6651	MS51957-27	96906 SCREW,MACHINE	EA	2
21	25	PAOZZ	5310-00-929-6395	310-0071-000	79807 WASHER,LOCK	EA	2
21	26	XDOZZ		756-8958-001	13499 POST,ELECTRICAL-MEC	EA	1
21	27	XDOZZ		756-8929-001	13499 PLATE,RETAINING	EA	2
21	28	PAOZZ	6625-00-058-3841	761-7006-002	13499 SHAFT AND PIN ASSEM	FT	3
21	29	PAOZZ	5821-00-043-1974	549-3662-002	13499 INSERT,FLEXIBLE COU	EA	3
21	30	PAOZZ	6625-00-058-3811	756-8926-001	13499 RETAINER,COUPLING	EA	3
21	31	PAOZZ	5330-00-824-9130	213-141216-00-2303	78189 PACKING PERFORMED	EA	3



EL4HK044

Figure 22. Extender, Module MX-4906/ARC-51X.

SECTION II

(1) ILLUSTRATION (A) FIG NO	(2) (B) ITEM NO	(3) SMR CODE	(4) NATIONAL STOCK NUMBER	(5) PART NUMBER	(6) DESCRIPTION FSCM	(7) USABLE ON CODE U/M	(8) QTY INC IN UNIT
GROUP 0708 EXTENDER,MODULE MX-4906/ARC-51X							
22	1	PAOZZ	5935-00-954-4470	SKT41WHITE	98291 JACK,TIP	EA	7
22	2	PAOZZ	5935-00-061-1363	SKT41RED	98291 JACK,TIP	EA	2
22	3	XDOOO		761-7003-001	13499 CABLE ASSEMBLY	EA	4
22	4	XDOZZ		756-8933-001	13499 CHASSIS,MDL EXT	EA	1
22	5	PAOZZ	5935-00-885-6505	DM53740-5000	71468 CONNECTOR,PLUG,ELEC	EA	4
22	6	PAOZZ	5935-00-710-1717	DE9P	71468 CONNECTOR,RECEPTACL	EA	1
22	7	PAOZZ	5310-00-938-2013	MS35649-24	96906 NUT,PLAIN,HEXAGON	EA	4
22	8	PAOZZ	5305-00-727-8833	MS51959-3	96906 SCREW,MACHINE	EA	2
22	9	XDOOO		761-7002-001	13499 WIRING HARNESS	EA	1
22	10	PAOZZ	6625-00-058-3811	756-8926-001	13499 RETAINER,COUPLING	EA	1
22	11	PAOZZ	5330-00-824-9130	213-141216-00-2303	78189 PACKING PERFORMED	EA	1
22	12	PAOZZ	5365-00-695-2558	340-0642-00	91314 RING,RETAINING	EA	2
22	13	PAOZZ	5340-00-479-9197	MS122119	96906 INSERT,SCREW THREAD	EA	2
22	14	PAOZZ	5305-00-909-1949	756-8924-001	13499 SCREW,CAP, SOCKET HE	EA	2
22	15	PAOZZ	6625-00-058-3841	761-7006-002	13499 SHAFT AND PIN ASSEM	EA	1
22	16	PAOZZ	5310-00-058-2949	310-0278-000	70318 WASHER,LOCK	EA	4
22	17	PAOZZ	5305-00-054-5646	MS51957-12	96906 SCREW,MACHINE	EA	4
22	18	XDOZZ		756-8922-001	13499 PLATE,RING,SFT	EA	1
22	19	PAOZZ	5821-00-021-4832	549-3856-002	13499 INSERT,FLEXIBLE COU	EA	1
22	20	XDOZZ		756-8927-001	13499 PIN,LOCATING	EA	2
22	21	PAOZZ	5315-00-291-5471	MS16562-189	96906 PIN,SPRING	EA	4
22	22	XDOZZ		CA5123-1	71468 PLATE ASSEMBLY	EA	1
22	23	PAOZZ	5305-00-763-3356	MS51959-5	96906 SCREW,MACHINE	EA	2
22	24	PAOZZ	5310-00-907-0959	310-6320-000	79847 WASHER,FLAT	EA	2
22	25	PAOZZ	5310-00-928-2690	310-0070-000	79807 WASHER,LOCK	EA	4
22	26	PAOZZ	5935-00-901-5204	DEF9S	71468 CONNECTOR,RECEPTACL	EA	1
22	27	PAOZZ	5935-00-080-0268	DM53742-5000	71468 CONNECTOR,PLUG,ELEC	EA	4
22	28	PAOZZ	5340-00-058-3808	756-8923-001	13499 POST,ELECTRICAL-MEC	EA	1
22	29	XDOZZ		756-8925-001	13499 COVER,MDL EXTEN	EA	1
22	30	PAOZZ	5305-00-054-6651	MS51957-27	96906 SCREW,MACHINE	EA	2
22	31	PAOZZ	5310-00-929-6395	310-0071-000	79807 WASHER,LOCK	EA	2
22	32	XDOZZ		756-8925-002	13499 COVER,MDL EXTEN	EA	1

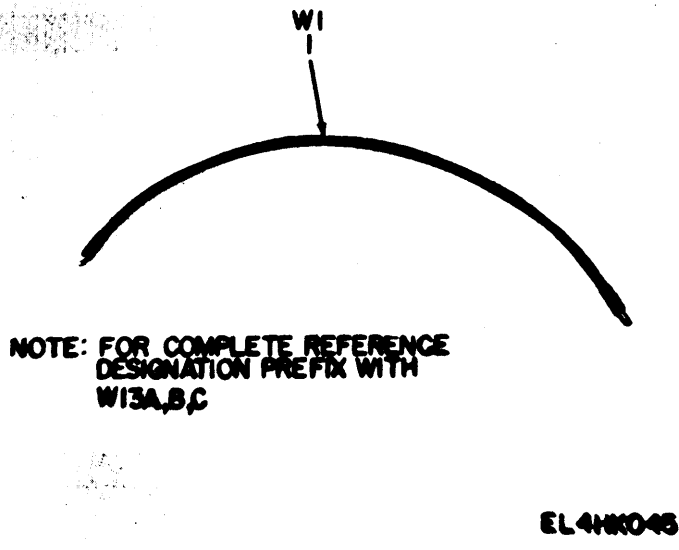

Figure 23. Cable Assembly, RF CG-3120/ARC-51 X.

SECTION II

(1)	(2)	(3)	(4)	(5)	(6)	(7)	(8)	
ILLUSTRATION							QTY	
(A)	(B)	NATIONAL			DESCRIPTION		INC	
FIG	ITEM	SMR	STOCK	PART			IN	
NO	NO	CODE	NUMBER	NUMBER	FSCM	USABLE ON CODE	U/M	UNIT

GROUP 08 CABLE ASSEMBLY,RF CG-3120/ARC-51X

23	1	XDOZZ		CA53693-80	71468	CABLE ASSEMBLY,RADI	EA	1
----	---	-------	--	------------	-------	---------------------	----	---

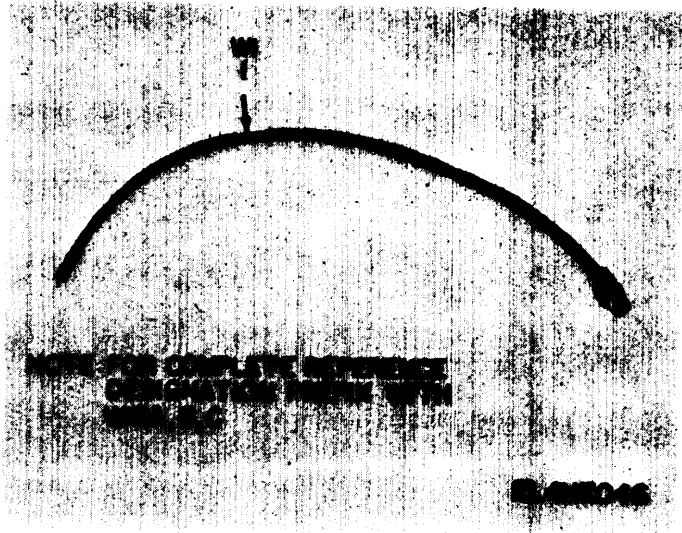

Figure 24. Cable Assembly, RF CG-3119/ARC-51X,

SECTION II

(1)	(2)	(3)	(4)	(5)	(6)	(7)	(8)	
ILLUSTRATION							QTY	
(A)	(B)	NATIONAL			DESCRIPTION		INC	
FIG	ITEM	SMR	STOCK	PART			IN	
NO	NO	CODE	NUMBER	NUMBER	FSCM	USABLE ON CODE	U/M	UNIT

GROUP 09 CABLE ASSEMBLY,MF CG-3119/ARC-51X

24	1	PAOZZ	6625-00-823-5343	CA53693-79	71468	CABLE ASSEMBLY,RADI	EA	1
----	---	-------	------------------	------------	-------	---------------------	----	---

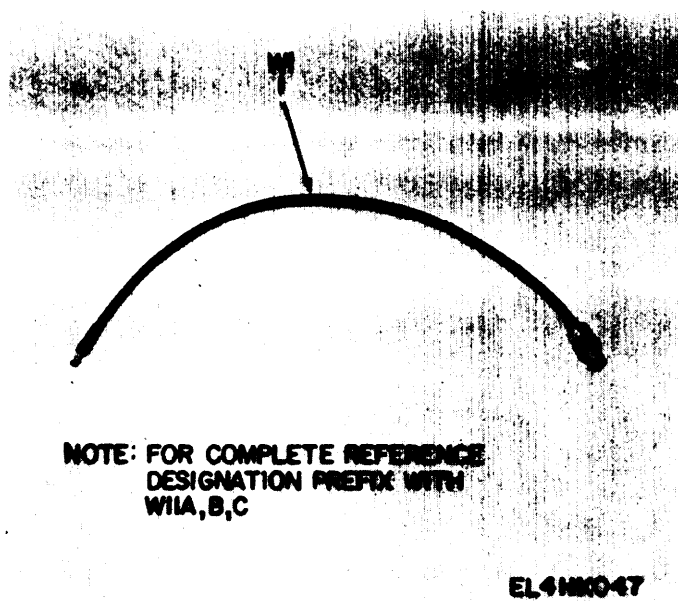

Figure 25. Cable Assembly, RF CG-3118/ARC-51X.

SECTION II

(1)	(2)	(3)	(4)	(5)	(6)	(7)	(8)	
ILLUSTRATION							QTY	
(A)	(B)	NATIONAL			DESCRIPTION		INC	
FIG	ITEM	SMR	STOCK	PART			IN	
NO	NO	CODE	NUMBER	NUMBER	FSCM	USABLE ON CODE	U/M	UNIT

GROUP 10 CABLE ASSEMBLY,RF CG-3118/ARC-51X

25	1	PAOZZ	6625-00-823-5342	CA53693-78	71468	CABLE ASSEMBLY,RADI	EA	1
----	---	-------	------------------	------------	-------	---------------------	----	---

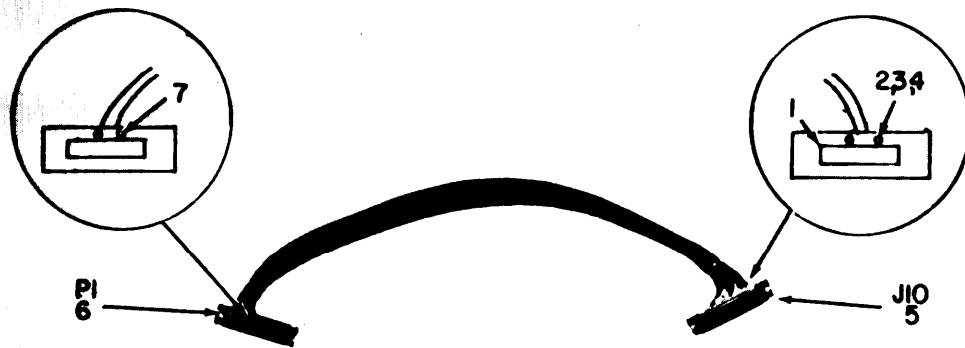

**NOTE: FOR COMPLETE REFERENCE
DESIGNATION PREFIX WITH WIO**

EL4HK048

Figure 26. Cable Assembly, Special Purpose, Electrical CX-10191/ARC-51X.

SECTION II

(1)	(2)	(3)	(4)	(5)	(6)	(7)	(8)	
ILLUSTRATION							QTY	
(A)	(B)	NATIONAL			DESCRIPTION		INC	
FIG	ITEM	STOCK	PART				IN	
NO	NO	CODE	NUMBER	NUMBER	FSCM	USABLE ON CODE	U/M	UNIT

GROUP 11 CABLE ASSEMBLY,SPECIAL PURPOSE,

ELECTRICAL CX-10191/ARC-51X

26	1	PAOZZ	5935-00-722-4350	DB-24659	71768	SHIELD,ELEC CON	EA	2
26	2	PAOZZ	5310-00-622-1724	68-1660-26	72962	NUT,SELF-LOCKING,HE	EA	4
26	3	PAOZZ	5305-00-054-5638	MS51957-4	96906	SCREW,MACHINE	EA	2
26	4	PAOZZ	5310-00-929-1748	310-0129-00	05411	WASHER,FLAT	EA	4
26	5	PAOZZ	5935-00-883-0218	DBMF25S	71768	CONNECTOR,RCPT	EA	1
26	6	PAOZZ	5935-01-029-7458	DBM25P	71468	CONNECTOR,RECEPTACL	EA	1
26	7	PAOZZ	5305-00-727-8833	MS51959-3	96906	SCREW,MACHINE	EA	2

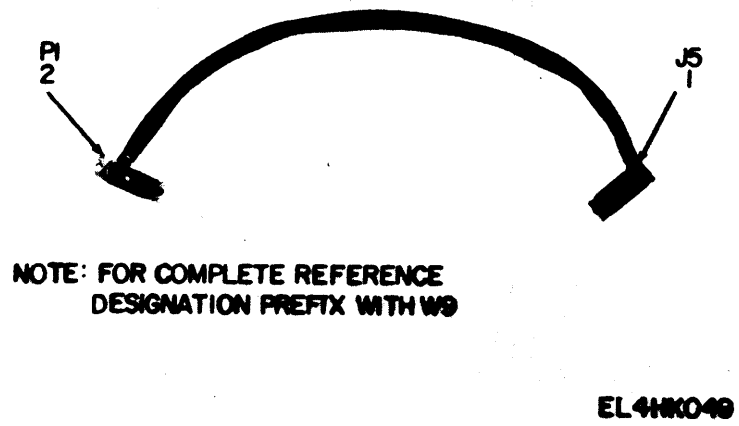

Figure 27. Cable Assembly, Special Purpose, Electrical CX-10190/ARC-51X.

SECTION II

(1)	(2)	(3)	(4)	(5)	(6)	(7)	(8)	
ILLUSTRATION							QTY	
(A)	(B)	NATIONAL			DESCRIPTION		INC	
FIG	ITEM	SMR	STOCK	PART			IN	
NO	NO	CODE	NUMBER	NUMBER	FSCM	USABLE ON CODE	U/M	UNIT

GROUP 12 CABLE ASSEMBLY, SPECIAL PURPOSE,

ELECTRICAL CX-10190/ARC-51X

27	1	PAOZZ	5935-00-059-2640	DAMF11W1S	71468	CONNECTOR, RECEPTACL	EA	1
27	2	PAOZZ	5935-00-901-5850	DAM11W1P	71468	CONNECTOR, RECEPTACL	EA	1

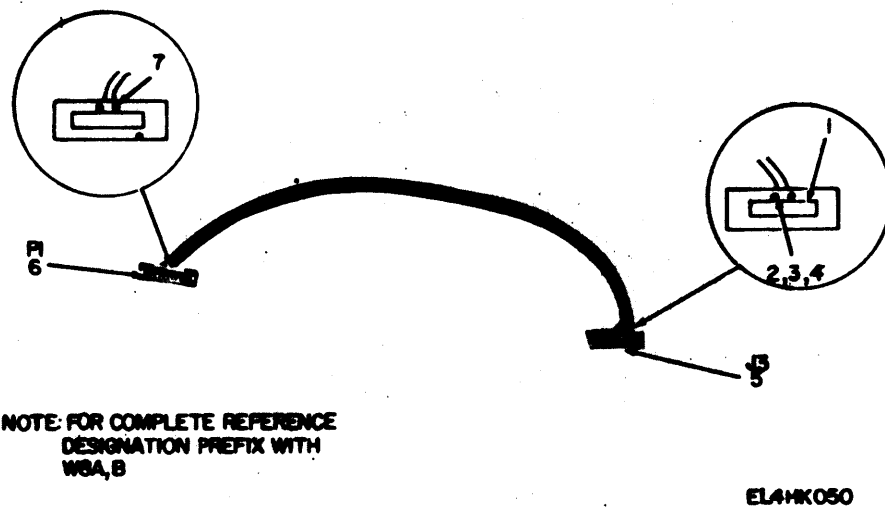

Figure 28. Cable Assembly, Special Purpose, Electrical CX-101/89/ARC-51X.

SECTION II

(1)	(2)	(3)	(4)	(5)	(6)	(7)	(8)	
ILLUSTRATION							QTY	
(A)	(B)	NATIONAL			DESCRIPTION		INC	
FIG	ITEM	SMR	STOCK	PART			IN	
NO	NO	CODE	NUMBER	NUMBER	FSCM	USABLE ON CODE	U/M	UNIT

GROUP 13 CABLE ASSEMBLY,SPECIAL PURPOSE,

ELECTRICAL CX-10189/ARC-51X

28	1	PAOZZ	5935-00-722-4348	024658-0000	71468	SHIELD,ELECTRICAL C	EA	2
28	2	PAOZZ	5310-00-622-1724	68-1660-26	72962	NUT,SELF-LOCKING,HE	EA	4
28	3	PAOZZ	5305-00-727-8833	MS51959-3	96906	SCREW,MACHINE	EA	2
28	4	PAOZZ	5310-00-929-1748	310-0129-00	05411	WASHER,FLAT	EA	4
28	5	PAOZZ	5935-00-993-2181	DAF15S	71468	CONNECTOR,RECEPTACL	EA	1
28	6	PAOZZ	5935-00-057-2690	DA15P	71468	CONNECTOR,RECEPTACL	EA	1
28	7	PAOZZ	5305-00-054-5638	MS51957-4	96906	SCREW,MACHINE	EA	2

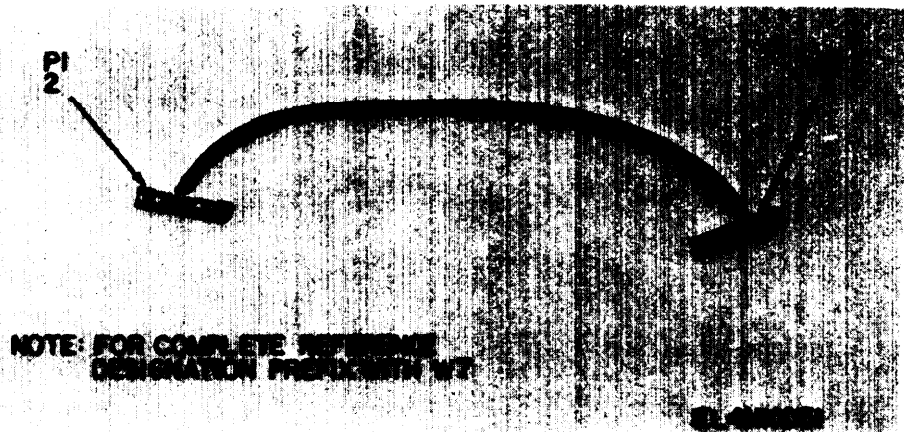

Figure 29. Cable Assembly, Special Purpose, Electrical CX-10188/ARC-51X.

SECTION II

(1)	(2)	(3)	(4)	(5)	(6)	(7)	(8)	
ILLUSTRATION							QTY	
(A)	(B)	NATIONAL			DESCRIPTION		INC	
FIG	ITEM	SMR	STOCK	PART			IN	
NO	NO	CODE	NUMBER	NUMBER	FSCM	USABLE ON CODE	U/M	UNIT

GROUP 14 CABLE ASSEMBLY,SPECIAL PURPOSE,

ELECTRICAL CX-10188/ARC-51X

29	1	PAOZZ	5935-00-089-1165	DBMF13W3S	71468	CONNECTOR,RECEPTACL	EA	1
29	2	PAOZZ	5935-00-811-1382	DBM13W3P	71468	CONNECTOR,RECEPTACL	EA	1

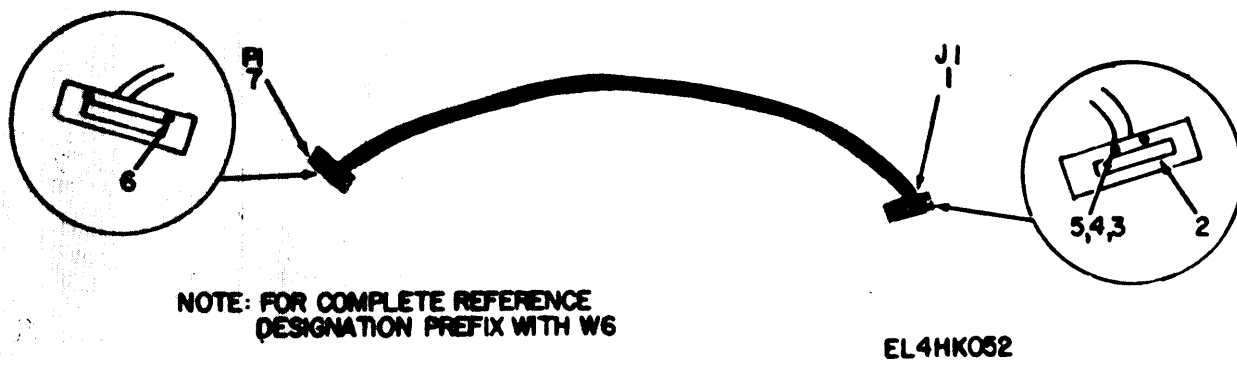

Figure 30. Cable Assembly, Special Purpose, Electrical CX-10187/ARC-51X.

SECTION II

(1)	(2)	(3)	(4)	(5)	(6)	(7)	(8)	
ILLUSTRATION							QTY	
(A)	(B)	NATIONAL			DESCRIPTION		INC	
FIG	ITEM	SMR	STOCK	PART			IN	
NO	NO	CODE	NUMBER	NUMBER	FSCM	USABLE ON CODE	U/M	UNIT

GROUP 15 CABLE ASSEMBLY,SPECIAL PURPOSE,

ELECTRICAL CX-10187/ARC-51X

30	1	PAOZZ	5935-00-901-5204	DEF9S	71468	CONNECTOR,RECEPTACL	EA	1
30	2	PAOZZ	5935-00-716-6591	024657-0000	71468	SHIELD,ELECTRICAL C	EA	2
30	3	PAOZZ	5310-00-622-1724	68-1660-26	72962	NUT,SELF-LOCKING,HE	EA	4
30	4	PAOZZ	5305-00-054-5638	MS51957-4	96906	SCREW,MACHINE	EA	2
30	5	PAOZZ	5310-00-929-1748	310-0129-00	05411	WASHER,FLAT	EA	4
30	6	PAOZZ	5305-00-727-8833	MS51959-3	96906	SCREW,MACHINE	EA	2
30	7	PAOZZ	5935-00-710-1717	DE9P	71468	CONNECTOR,RECEPTACL	EA	1

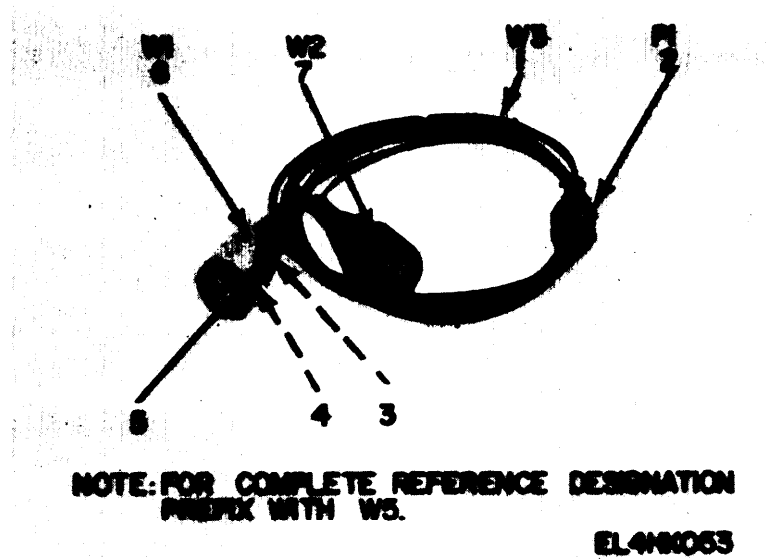

Figure 31. Cable Assembly, Power, Electrical, Branched CX-10186/ARC-51X.

SECTION II

(1)	(2)	(3)	(4)	(5)	(6)	(7)	(8)	
ILLUSTRATION							QTY	
(A)	(B)	NATIONAL			DESCRIPTION		INC	
FIG	ITEM	SMR	STOCK	PART			IN	
NO	NO	CODE	NUMBER	NUMBER	FSCM	USABLE ON CODE	U/M	UNIT

GROUP 16 CABLE ASSEMBLY, POWER, ELECTRICAL,

BRANCHED CX-10186/ARC-51X

31	1	XDOZZ		T5975	71124	CABLE, SP, ELEC	FT	1
31	2	PAOZZ	5935-00-901-8871	MS3116F12-3S	96906	CONNECTOR, PLUG, ELEC	EA	1
31	3	PAOZZ	5940-00-143-4774	31902	00779	TERMINAL, LUG	EA	2
31	4	PAOZZ	5310-00-190-7693	310-0079-000	79807	WASHER, LOCK	EA	2
31	5	PAOZZ	5940-00-941-1933	24A	76545	CLIP, ELECTRICAL	EA	2
31	6	PAOZZ	5975-00-281-0034	26	76545	CABLE NIPPLE, EL	EA	1
31	7	XDOZZ		26BLK	76545	CABLE NIPPLE, EL	EA	1

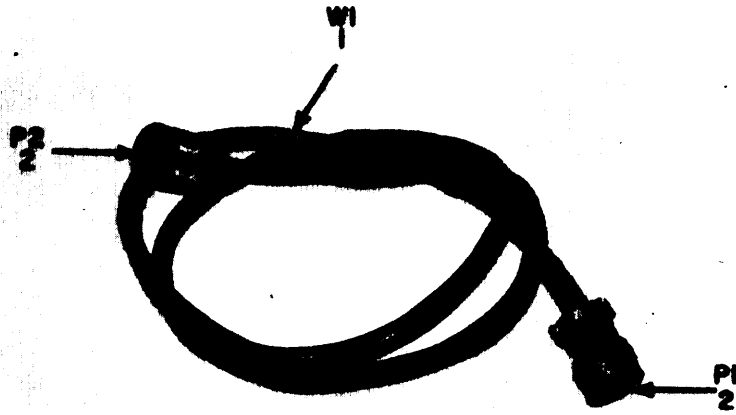

**NOTE: FOR COMPLETE REFERENCE DESIGNATION
PREFIX WITH W4.**

EL418054

Figure 32. Cable Assembly, Special Purpose, Electrical CX-10185/ARC-51X.

SECTION II

(1)	(2)	(3)	(4)	(5)	(6)	(7)	(8)	
ILLUSTRATION							QTY	
(A)	(B)	NATIONAL			DESCRIPTION		INC	
FIG	ITEM	SMR	STOCK	PART			IN	
NO	NO	CODE	NUMBER	NUMBER	FSCM	USABLE ON CODE	U/M	UNIT
					GROUP 17 CABLE ASSEMBLY,SPECIAL PURPOSE,			
					ELECTRICAL CX-10185/ARC-51X			
32	1	XDOZZ		T6009	71124 CABLE,SP,ELEC		FT	1
32	2	PAOZZ	5935-00-717-2591	MS3116F18-32S	96906 CONNECTOR,PLUG,ELEC		EA	2

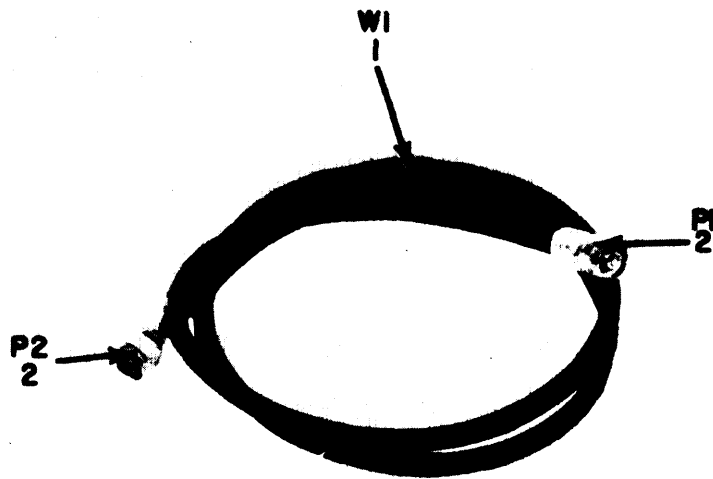

**NOTE: FOR COMPLETE REFERENCE DESIGNATION
PREFIX WITH W3.**

EL4HK065

Figure 33. Cable Assembly, RF CG-1889/U.

SECTION II

(1)	(2)	(3)	(4)	(5)	(6)	(7)	(8)
ILLUSTRATION							QTY
(A)	(B)		NATIONAL				INC
FIG	ITEM	SMR	STOCK	PART		DESCRIPTION	IN
NO	NO	CODE	NUMBER	NUMBER	FSCM	USABLE ON CODE	U/M UNIT

GROUP 18 CABLE ASSEMBLY,RF CG-1889/U

33	1	PAOZZ	6145-00-660-8711	RG213U	80058	CABLE,RADIO FREQUEN	FT	1
33	2	PAOZZ	5935-00-577-8776	UG21EU	80058	CONNECTOR	EA	2

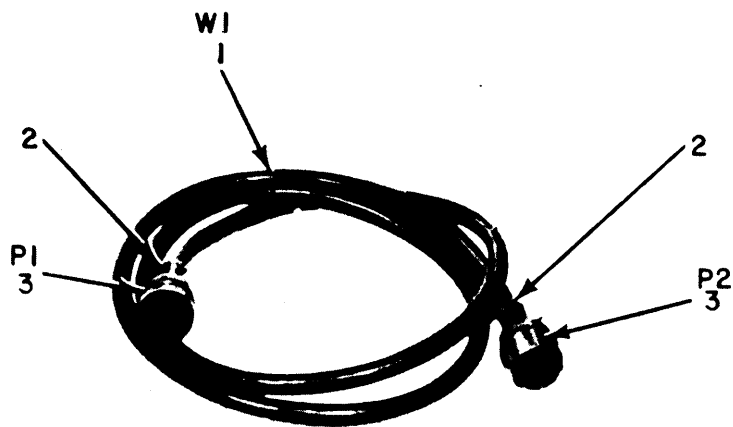

**NOTE: FOR COMPLETE REFERENCE DESIGNATION
PREFIX WITH W2**

EL4HK056

Figure 34. Cable Assembly, Special Purpose, Electrical CX-9053/ARC-51X.

SECTION II

(1)	(2)	(3)	(4)	(5)	(6)	(7)	(8)	
ILLUSTRATION							QTY	
(A)	(B)	NATIONAL			DESCRIPTION		INC	
FIG	ITEM	SMR	STOCK	PART			IN	
NO	NO	CODE	NUMBER	NUMBER	FSCM	USABLE ON CODE	U/M	UNIT

GROUP 19 CABLE ASSEMBLY, SPECIAL PURPOSE,

ELECTRICAL CX-9053/ARC-51X

34	1	XDOZZ		T6010	71124	CABLE, SP, ELEC	FT	1
34	2	XDOZZ		761-5950-001	13499	SLEEVE, EXTENSIO	EA	2
34	3	PAOZZ	5935-00-903-3513	PTO6E16-26SWR	77820	CONNECTOR, PLUG, ELEC	EA	2

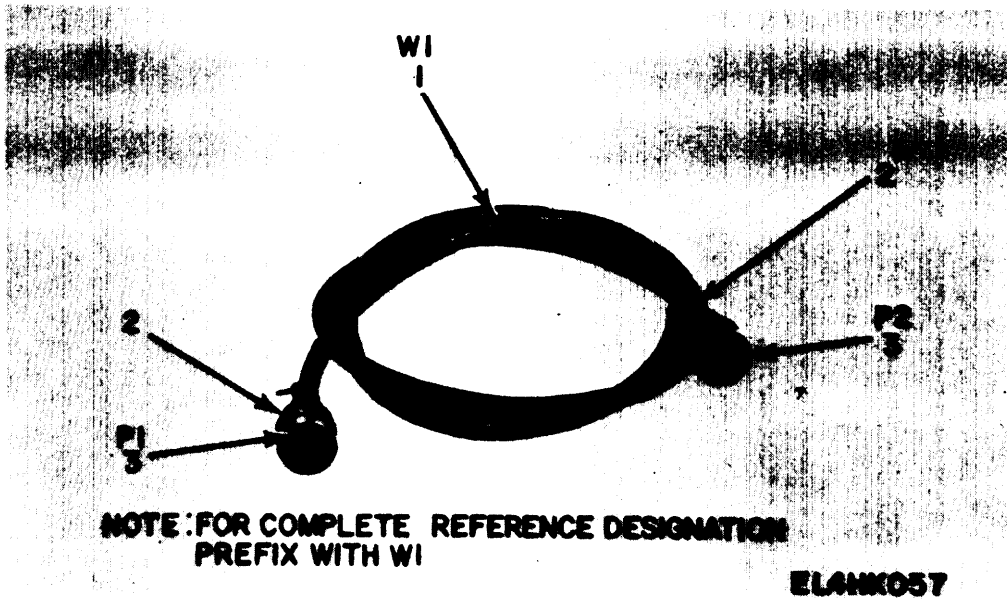

Figure 35. Cable Assembly, Special Purpose, Electrical CX-9052/ARC-51X.

SECTION II

(1)	(2)	(3)	(4)	(5)	(6)	(7)	(8)	
ILLUSTRATION							QTY	
(A)	(B)	NATIONAL			DESCRIPTION		INC	
FIG	ITEM	SMR	STOCK	PART			IN	
NO	NO	CODE	NUMBER	NUMBER	FSCM	USABLE ON CODE	U/M	UNIT
					GROUP 20 CABLE ASSEMBLY,SPECIAL PURPOSE,			
					ELECTRICAL CX-9052/ARC-51X			
35	1	XDOZZ		T6010	71124 CABLE, SP, ELEC		FT	1
35	2	XDOZZ		761-5950-001	13499 SLEEVE, EXTENSIO		EA	2
35	3	PAOZZ	5935-00-903-3512	PTO6E16-26 SSR	77820 CONNECTOR, PLUG, ELEC		EA	2

SECTION IV

NATIONAL STOCK NUMBER AND PART NUMBER INDEX

NOTE: LATEST NATIONAL STOCK NUMBER AND PART NUMBER ASSIGNMENTS ARE INCLUDED AT END OF INDEX.

STOCK NUMBER	FIGURE NO	ITEM NO	STOCK NUMBER	FIGURE NO	ITEM NO
5120-00-013-7117	4	18	5325-00-174-5317	14	33
3040-00-016-2719	1	25	5310-00-208-3786	14	20
5821-00-021-4832	17	38	5310-00-275-5147	9	21
5821-00-021-4832	18	23	5905-00-279-1756	9	25
5821-00-021-4832	22	19	5325-00-290-3969	9	3
5120-00-022-7793	4	23	5315-00-291-5471	15	16
5821-00-043-1974	21	29	5315-00-291-5471	16	24
5305-00-054-5635	9	6	5315-00-291-5471	17	23
5305-00-054-5635	14	29	5315-00-291-5471	18	25
5305-00-054-5635	15	4	5315-00-291-5471	19	14
5305-00-054-5635	16	11	5315-00-291-5471	20	12
5305-00-054-5635	17	25	5315-00-291-5471	21	5
5305-00-054-5635	18	17	5315-00-291-5471	22	21
5305-00-054-5638	1	13	5315-00-297-0875	4	22
5305-00-054-5638	26	3	5995-00-467-3887	3	3
5305-00-054-5638	28	7	5340-00-479-9197	15	17
5305-00-054-5638	30	4	5340-00-479-9197	16	9
5305-00-054-5646	14	31	5340-00-479-9197	17	28
5305-00-054-5646	17	4	5340-00-479-9197	18	14
5305-00-054-5646	18	20	5340-00-479-9197	19	15
5305-00-054-5646	21	20	5340-00-479-9197	20	13
5305-00-054-5646	22	17	5340-00-479-9197	21	9
5305-00-054-5647	11	3	5340-00-479-9197	22	13
5305-00-054-5647	12	3	5310-00-515-8243	9	33
5305-00-054-5648	14	9	5310-00-550-3715	1	17
5305-00-054-5649	14	28	5935-00-577-8776	33	2
5305-00-054-5650	14	27	5120-00-618-4433	4	6
5305-00-054-5651	2	4	5310-00-622-1724	26	2
5305-00-054-5653	14	21	5310-00-622-1724	28	2
5305-00-054-6651	9	15	5310-00-622-1724	30	3
5305-00-054-6651	15	22	6145-00-660-8711	33	1
5305-00-054-6651	16	4	5365-00-695-2558	1	22
5305-00-054-6651	17	11	5365-00-695-2558	15	12
5305-00-054-6651	18	9	5365-00-695-2558	16	14
5305-00-054-6651	19	5	5365-00-695-2558	17	29
5305-00-054-6651	20	6	5365-00-695-2558	18	13
5305-00-054-6651	21	24	5365-00-695-2558	19	11
5305-00-054-6651	22	30	5365-00-695-2558	20	15
5305-00-054-6652	9	2	5365-00-695-2558	21	13
5305-00-054-6672	1	26	5365-00-695-2558	22	12
5935-00-057-2690	15	7	5355-00-702-2704	9	1
5935-00-057-2690	17	33	5935-00-710-1717	22	6
5935-00-057-2690	19	10	5935-00-710-1717	30	7
5935-00-057-2690	20	19	5935-00-716-6591	30	2
5935-00-057-2690	28	6	5935-00-717-2591	32	2
5340-00-058-3808	22	28	5305-00-719-5342	5	4
6625-00-058-3811	17	39	5305-00-719-5342	9	8
6625-00-058-3811	18	22	5120-00-720-1908	4	17
6625-00-058-3811	21	30	5935-00-722-4348	28	1
6625-00-058-3811	22	10	5340-00-722-8713	14	25
6625-00-058-3841	17	37	5985-00-726-2290	1	4
6625-00-058-3841	21	28	5305-00-727-8833	15	19
6625-00-058-3841	22	15	5305-00-727-8833	16	19
5935-00-059-2640	16	8	5305-00-727-8833	17	30
5935-00-059-2640	18	28	5305-00-727-8833	18	7
5935-00-059-2640	27	1	5305-00-727-8833	19	17
5935-00-061-1363	15	21	5305-00-727-8833	20	18
5935-00-061-1363	17	2	5305-00-727-8833	21	17
5935-00-061-1363	18	2	5305-00-727-8833	22	8
5935-00-061-1363	19	20	5305-00-727-8833	26	7
5935-00-061-1363	22	2	5305-00-727-8833	28	3
5935-00-080-0268	16	16	5305-00-727-8833	30	6
5935-00-080-0268	17	20	6625-00-738-5973	1	1
5935-00-080-0268	18	29	6625-00-738-5975	14	15
5935-00-080-0268	21	1	6625-00-738-5976	1	6
5935-00-080-0268	22	27	6625-00-738-5977	14	14
5935-00-088-9619	17	35	6625-00-738-5978	14	16
5935-00-089-1165	21	18	6625-00-738-5979	14	13
5935-00-089-1165	29	1	6625-00-738-5980	14	12
5935-00-089-6505	17	32	6625-00-738-5981	14	18
5935-00-089-6921	17	19	6625-00-738-5982	14	11
6625-00-089-7164	1	1	6625-00-738-5983	14	17
5940-00-143-4774	31	3	6625-00-738-5984	2	6
6625-00-143-6716	5	1	6625-00-738-5986	2	2
5140-00-152-2514	4	3	6625-00-738-5989	2	1
5120-00-152-2516	4	1	6625-00-738-5990	2	3
6240-00-155-7836	5	16	6625-00-738-5991	1	3
6240-00-155-7836	6	40	6625-00-738-5991	13	1
6240-00-155-7836	8	2	5180-00-738-6019	1	7
5905-00-171-1975	9	24	5935-00-762-9306	3	8

SECTION IV

NATIONAL STOCK NUMBER AND PART NUMBER INDEX

STOCK NUMBER	FIGURE	ITEM	STOCK NUMBER	FIGURE	ITEM
	NO	NO		NO	NO
5935-00-762-9307	3	11	5310-00-928-2690	9	17
5305-00-763-3356	15	8	5310-00-928-2690	15	9
5305-00-763-3356	16	6	5310-00-928-2690	16	7
5305-00-763-3356	17	17	5310-00-928-2690	18	32
5305-00-763-3356	18	30	5310-00-928-2690	19	9
5305-00-763-3356	19	7	5310-00-928-2690	20	10
5305-00-763-3356	20	8	5310-00-928-2690	21	12
5305-00-763-3356	21	10	5310-00-928-2690	22	25
5305-00-763-3356	22	23	5310-00-929-1748	26	4
5305-00-763-6962	9	19	5310-00-929-1748	28	4
5305-00-763-7822	14	4	5310-00-929-1748	30	5
5305-00-764-2964	9	14	5310-00-929-6395	9	34
5305-00-764-2966	1	27	5310-00-929-6395	15	23
6210-00-767-6246	5	17	5310-00-929-6395	16	5
6210-00-767-6246	8	3	5310-00-929-6395	17	12
5305-00-777-6039	14	26	5310-00-929-6395	18	10
5935-00-811-1382	21	8	5310-00-929-6395	19	6
5935-00-811-1382	29	2	5310-00-929-6395	20	7
5935-00-823-0212	11	2	5310-00-929-6395	21	25
6625-00-823-5342	25	1	5310-00-929-6395	22	31
6625-00-823-5343	24	1	5340-00-930-0107	14	8
5935-00-835-3031	12	2	5340-00-930-0835	14	24
4320-00-854-4444	4	14	5310-00-933-8118	14	32
5935-00-881-9480	17	7	5310-00-938-2013	1	12
5935-00-885-6505	16	10	5310-00-938-2013	1	20
5935-00-885-6505	17	26	5310-00-938-2013	9	13
5935-00-885-6505	18	4	5310-00-938-2013	15	10
5935-00-885-6505	21	7	5310-00-938-2013	16	18
5935-00-885-6505	22	5	5310-00-938-2013	17	16
5935-00-901-5204	22	26	5310-00-938-2013	18	6
5935-00-901-5204	30	1	5310-00-938-2013	19	16
5935-00-901-5850	16	17	5310-00-938-2013	20	17
5935-00-901-5850	18	5	5310-00-938-2013	21	16
5935-00-901-5850	27	2	5310-00-938-2013	22	7
5935-00-901-8871	31	2	5140-00-944-7205	4	8
5935-00-903-3512	35	3	5140-00-944-7206	4	7
5935-00-903-3513	34	3	5930-00-944-9835	9	27
5935-00-906-6335	9	9	5930-00-944-9836	9	30
6625-00-906-6365	5	18	5930-00-944-9837	9	11
6625-00-906-6366	5	1	5930-00-944-9838	9	32
6625-00-906-6367	5	5	5340-00-946-9442	14	2
5140-00-906-6373	4	26	5120-00-952-0108	4	11
5120-00-906-6376	4	25	5905-00-954-6432	9	20
5120-00-906-6377	4	4	5905-00-954-6899	9	26
5120-00-906-6379	4	5	5935-00-959-1457	4	15
5120-00-906-6380	4	24	5120-00-963-7661	4	2
5120-00-908-4752	4	10	6625-00-965-1483	1	5
5120-00-908-4752	4	10	6625-00-965-1483	1	5
5120-00-908-4754	4	27	6625-00-985-8078	3	5
5821-00-908-4758	7	3	6625-00-985-8079	3	6
5355-00-908-4763	5	3	6625-00-985-8080	3	7
4910-00-908-6709	4	16	5995-00-985-8081	3	4
6625-00-908-7384	7	4	6625-00-985-8082	3	17
6625-00-908-7390	7	2	6625-00-985-8083	3	2
6625-00-908-7393	5	2	6625-00-985-8084	3	16
5355-00-909-0465	5	21	6625-00-985-8085	3	15
5355-00-909-0465	9	5	6625-00-985-8086	3	14
5305-00-909-1949	15	13	6625-00-985-8088	3	12
5305-00-909-1949	16	13	5935-00-990-6983	4	21
5305-00-909-1949	17	27	5935-00-993-2181	15	20
5305-00-909-1949	18	15	5935-00-993-2181	17	15
5305-00-909-1949	19	12	5935-00-993-2181	19	18
5305-00-909-1949	20	14	5935-00-993-2181	20	2
5305-00-909-1949	21	14	5935-00-993-2181	28	5
5305-00-909-1949	22	14	5935-01-029-7458	26	6
5310-00-928-2690	1	15	5935-01-035-5650	3	9

PART NUMBER	FSCM	FIG NO	ITEM NO	PART NUMBER	FSCM	FIG NO	ITEM NO
AS1484ARC51X	80058	1	4	CX10185ARC51X	80058	3	16
CA5123-1	71468	22	22	CX10186ARC51X	80058	3	1
CA53693-78	71468	25	1	CX10187ARC51X	80058	3	15
CA53693-79	71468	24	1	CX10188ARC51X	80058	3	14
CA53693-80	71468	23	1	CX10189ARC51X	80058	3	13
CETC6B	71468	4	2	CX10190ARC51X	80058	3	12
CG1889U5FT	80058	3	3	CX10191ARC51X	80058	3	4
CG3118ARC51X	80058	3	5	CX9052ARC51X	80058	3	17
CG3119ARC51X	80058	3	6	CX9053ARC51X	80058	3	2
CG3120ARC51X	80058	3	7	DAF15S	71468	15	20

SECTION IV

NATIONAL STOCK NUMBER AND PART NUMBER INDEX

PART NUMBER	FSCM	FIG NO	ITEM NO	PART NUMBER	FSCM	FIG NO	ITEM NO
DAF15S	71468	17	15	MS35649-24	96906	20	17
DAF15S	71468	19	18	MS35649-24	96906	21	16
DAF15S	71468	20	2	MS35649-24	96906	22	7
DAF15S	71468	28	5	MS51957-1	96906	9	6
DAMF11W1S	71468	16	8	MS51957-1	96906	14	29
DAMF11W1S	71468	18	28	MS51957-1	96906	15	4
DAMF11W1S	71468	27	1	MS51957-1	96906	16	11
DAMF3W3S	71468	17	19	MS51957-1	96906	17	25
DAM11W1P	71468	16	17	MS51957-1	96906	18	17
DAM11W1P	71468	18	5	MS51957-12	96906	14	31
DAM11W1P	71468	27	2	MS51957-12	96906	17	4
DAM3W3P	71468	17	32	MS51957-12	96906	18	20
DA15P	71468	15	7	MS51957-12	96906	21	20
DA15P	71468	17	33	MS51957-12	96906	22	17
DA15P	71468	19	10	MS51957-13	96906	11	3
DA15P	71468	20	19	MS51957-13	96906	12	3
DA15P	71468	28	6	MS51957-14	96906	14	9
DA397ARC51X	80058	1	3	MS51957-15	96906	14	28
DBMF13W3S	71468	21	18	MS51957-16	96906	14	27
DBMF13W3S	71468	29	1	MS51957-17	96906	2	4
				MS51957-19	96906	14	21
DBM13W3P	71468	21	8	MS51957-27	96906	9	15
DBM13W3P	71468	29	2	MS51957-27	96906	15	22
DBM25P	71468	26	6	MS51957-27	96906	16	4
DEF9S	71468	22	26	MS51957-27	96906	17	11
DEF9S	71468	30	1	MS51957-27	96906	18	9
DE9P	71468	22	6	MS51957-27	96906	19	5
DE9P	71468	30	7	MS51957-27	96906	20	6
DM53740-5000	71468	16	10	MS51957-27	96906	21	24
DM53740-5000	71468	17	26	MS51957-27	96906	22	30
DM53740-5000	71468	18	4	MS51957-28	96906	9	2
DM53740-5000	71468	21	7	MS51957-4	96906	1	13
DM53740-5000	71468	22	5	MS51957-4	96906	26	3
DM53742-5000	71468	16	16	MS51957-4	96906	28	7
DM53742-5000	71468	17	20	MS51957-4	96906	30	4
DM53742-5000	71468	18	29	MS51957-47	96906	1	26
DM53742-5000	71468	21	1	MS51959-12	96906	14	26
DM53742-5000	71468	22	27	MS51959-14	96906	14	4
F10-1	26848	4	6	MS51959-2	96906	1	27
GT1003	70276	4	11	MS51959-27	96906	9	19
				MS51959-3	96906	15	19
MS122119	96906	15	17	MS51959-3	96906	16	19
MS122119	96906	16	9	MS51959-3	96906	17	30
MS122119	96906	17	28	MS51959-3	96906	18	7
MS122119	96906	18	14	MS51959-3	96906	19	17
MS122119	96906	19	15	MS51959-3	96906	20	18
MS122119	96906	20	13	MS51959-3	96906	21	17
MS122119	96906	21	9	MS51959-3	96906	22	8
MS122119	96906	22	13	MS51959-3	96906	26	7
MS16562-189	96906	15	16	MS51959-3	96906	28	3
MS16562-189	96906	16	24	MS51959-3	96906	30	6
MS16562-189	96906	17	23	MS51959-4	96906	9	14
MS16562-189	96906	18	25	MS51959-5	96906	15	8
MS16562-189	96906	19	14	MS51959-5	96906	16	6
MS16562-189	96906	20	12	MS51959-5	96906	17	17
MS16562-189	96906	21	5	MS51959-5	96906	18	30
MS16562-189	96906	22	21	MS51959-5	96906	19	7
MS171444	96906	4	22	MS51959-5	96906	20	8
MS25237-327	96906	5	16	MS51959-5	96906	21	10
MS25237-327	96906	6	40	MS51959-5	96906	22	23
MS25237-327	96906	8	2	MS51981-26	96906	5	4
MS3112E16-26P	96906	12	2	MS51981-26	96906	9	8
MS3112E16-26PW	96906	11	2	MT3371ARC51X	80058	1	6
MS3116F12-3S	96906	31	2	MT3372ARC51X	80058	1	2
MS3116F18-32S	96906	32	2	MX4906ARC51X	80058	14	14
				MX4907ARC51X	80058	14	16
MS35333-70	96906	1	17	MX4908ARC51X	80058	14	13
MS35338-134	96906	1	15	MX4909ARC51X	80058	14	12
MS35338-134	96906	9	17	MX4910ARC51X	80058	14	18
MS35338-135	96906	14	32	MX4911ARC51X	80058	14	11
MS35338-136	96906	9	34	MX4912ARC51X	80058	14	17
MS35489-4	96906	14	33	MX4913ARC51X	80058	14	15
MS35649-24	96906	1	12	MX6731ARC51X	80058	2	6
MS35649-24	96906	1	20	MX6732ARC51X	80058	2	3
MS35649-24	96906	9	13	MX6733ARC51X	80058	2	1
MS35649-24	96906	15	10	MX6734ARC51X	80058	2	2
MS35649-24	96906	15	10	MX6734ARC51X	80058	2	2
MS35649-24	96906	16	18	NP9	08730	14	6
MS35649-24	96906	17	16	NX24427	71450	9	26
MS35649-24	96906	18	6	NX24429	71450	9	20
MS35649-24	96906	19	16	PT06E16-26 SSR	77820	35	3

TM11-6625-564-20P
SECTION IV
NATIONAL STOCK NUMBER AND PART NUMBER INDEX

PART NUMBER	FSCM	FIG NO	ITEM NO	PART NUMBER	FSCM	FIG NO	ITEM NO
PTO6E16-26SWSR	77820	34	3	310-6320-00	79807	16	20
P313-0132-00	77250	14	20	310-6320-00	79807	17	31
P334-4120-00	77250	9	21	310-6320-00	79807	18	31
RC20GF151K	81349	9	25	310-6320-00	79807	19	8
RC42GF151K	81349	9	24	310-6320-00	79807	20	9
RG213U	80058	33	1	310-6320-00	79807	21	11
RG303U	80058	17	36	310-6320-00	79847	22	24
SKT10WHT	98291	4	20	310000070000	79807	17	18
SKT41RED	98291	15	21	31902	00779	31	3
SKT41RED	98291	17	2	334-1656-00	06164	1	24
SKT41RED	98291	18	2	340-0642-00	91314	1	22
SKT41RED	98291	19	20	340-0642-00	91314	15	12
SKT41RED	98291	22	2	340-0642-00	91314	16	14
SM348AARC51X	80058	1	1	340-0642-00	91314	17	29
SM348ARC51X	80058	1	1	340-0642-00	91314	18	13
TK155ARC51X	80058	1	7	340-0642-00	91314	19	11
TS1962ARC51X	80058	1	5	340-0642-00	91314	20	15
T5975	71124	31	1	340-0642-00	91314	21	13
T6009	71124	32	1	340-0642-00	91314	22	12
T6010	71124	34	1	340-0644-00	91314	2	5
T6010	71124	35	1	505-1504-001	13499	9	22
UG21EU	80058	33	2	51-258	98278	17	7
UG29BU	81349	3	10	53-315	98278	17	9
U334ARC51X	80058	3	11	540-9168-003	13499	14	25
U335ARC51X	80058	3	8	541-5987-002	13499	14	22
U336ARC51X	80058	3	9	544-8352-002	13499	4	15
				544-8357-002	13499	4	27
024-0168-00	13499	4	17	544-8398-002	13499	4	10
024-0628-010	13499	4	26	547-1643-002	13499	1	25
024-0628-020	13499	4	3	547-1646-002	13499	1	18
024-0642-010	13499	4	9	547-1647-002	13499	1	23
024657-0000	71468	30	2	548-2214-002	13499	4	23
024658-0000	71468	28	1	548-9286-002	13499	4	18
052-0512	98278	17	35	549-3662-002	13499	21	29
				549-3856-002	13499	17	38
203B	83330	4	21	549-3856-002	13499	18	23
236922BA1	76854	9	32	549-3856-002	13499	22	19
236923BA1	76854	9	27	553-9709-002	13499	4	25
237164RK1	76854	9	11	6A49450	53800	4	14
238191RK2	76854	9	30	6018-124CN	91506	14	2
26BLK	76545	31	7	6019-41CN	91506	14	8
2600-8	71286	9	3	6020-11CN	91506	14	24
2600SW2	13499	9	4	68-1660-26	72962	26	2
310-0046-00	79807	9	33	68-1660-26	72962	28	2
310-0070-000	79807	15	9	68-1660-26	72962	30	3
310-0070-000	79807	16	7	713-0055-010	13499	13	1
310-0070-000	79807	18	32	7229	17875	4	16
310-0070-000	79807	19	9	756-7571-001	13499	4	24
310-0070-000	79807	20	10	756-7579-001	13499	4	5
310-0070-000	79807	21	12	756-7580-001	13499	4	4
310-0070-000	79807	22	25	756-8834-002	13499	9	18
310-0071-000	79807	15	23	756-8835-002	13499	9	28
310-0071-000	79807	16	5	756-8837-002	13499	9	29
310-0071-000	79807	17	12	756-8841-001	13499	9	9
310-0071-000	79807	18	10	756-8846-001	13499	9	10
310-0071-000	79807	19	6	756-8902-001	13499	20	5
310-0071-000	79807	20	7	756-8905-001	13499	20	3
310-0071-000	79807	21	25	756-8905-002	13499	20	4
310-0071-000	79807	22	31	756-8911-001	13499	18	12
310-0079-00	79807	31	4	756-8916-001	13499	18	8
310-0129-00	05411	26	4	756-8916-002	13499	18	11
310-0129-00	05411	28	4	756-8922-001	13499	17	3
310-0129-00	05411	30	5	756-8922-001	13499	18	19
310-0278-000	70318	11	4	756-8922-001	13499	21	19
310-0278-000	70318	12	4	756-8922-001	13499	22	18
310-0278-000	70318	17	5	756-8923-001	13499	22	28
310-0278-000	70318	18	21	756-8924-001	13499	15	13
310-0278-000	70318	21	21	756-8924-001	13499	16	13
310-0278-000	70318	22	16	756-8924-001	13499	17	27
310-6320-00	79807	1	14	756-8924-001	13499	18	15
310-6320-00	79807	9	16	756-8924-001	13499	19	12
310-6320-00	79807	15	18				

TM11-6625-564-20P
SECTION IV
NATIONAL STOCK NUMBER AND PART NUMBER INDEX

PART NUMBER	FSCM	FIG NO	ITEM NO	PART NUMBER	FSCM	FIG NO	ITEM NO
756-8924-001	13499	20	14	757-0231-001	13499	9	1
756-8924-001	13499	21	14	757-9783-000	13499	1	11
756-8924-001	13499	22	14	761-5944-001	13499	4	1
756-8925-001	13499	22	29	761-5945-001	13499	4	8
756-8925-002	13499	22	32	761-5947-001	13499	4	7
756-8926-001	13499	17	39	761-5950-001	13499	34	2
756-8926-001	13499	18	22	761-5950-001	13499	35	2
756-8926-001	13499	21	30	761-7002-001	13499	22	9
756-8926-001	13499	22	10	761-7003-001	13499	21	15
756-8927-001	13499	17	22	761-7003-001	13499	22	3
756-8927-001	13499	18	26	761-7003-002	13499	16	15
756-8927-001	13499	21	4	761-7003-002	13499	17	21
756-8927-001	13499	22	20	761-7003-002	13499	18	27
756-8927-002	13499	15	15	761-7005-001	13499	21	2
756-8927-002	13499	16	23	761-7006-002	13499	17	37
756-8927-002	13499	19	13	761-7006-002	13499	21	28
756-8927-002	13499	20	11	761-7006-002	13499	22	15
756-8928-001	13499	17	14	761-7008-001	13499	20	16
756-8929-001	13499	21	27	761-7010-001	13499	19	19
756-8933-001	13499	22	4	761-7012-001	13499	18	3
756-8936-001	13499	17	8	761-7014-001	13499	17	34
756-8937-001	13499	17	10	761-7016-001	13499	16	21
756-8942-001	13499	17	6	761-7018-001	13499	15	11
756-8942-002	13499	17	13	761-7019-001	13499	12	1
756-8952-001	13499	15	3	761-7020-001	13499	11	1
756-8952-001	13499	19	2	761-7025-001	13499	14	5
756-8952-002	13499	15	1	761-7026-001	13499	14	3
756-8952-002	13499	19	4	761-7040-001	13499	5	18
756-8958-001	13499	19	3	761-7043-001	13499	5	2
756-8958-001	13499	21	26	761-7044-001	13499	5	1
756-8963-001	13499	21	23	761-7062-001	13499	5	5
756-8964-001	13499	21	22	761-7064-001	13499	7	1
756-8967-001	13499	21	6	761-7065-001	13499	7	4
756-8969-001	13499	15	2	761-7066-001	13499	7	2
756-8970-001	13499	15	6	761-7069-001	13499	7	3
756-8978-001	13499	16	1	761-7078-001	13499	9	31
756-8982-002	13499	16	3	767-0745-000	13499	9	7
756-8985-001	13499	16	2	767-0747-010	13499	15	14
756-9020-001	13499	14	23	767-0748-010	13499	16	12
756-9021-001	13499	14	10	767-0754-008	13499	1	19
756-9024-001	13499	14	1	767-0758-010	13499	17	24
756-9032-001	13499	14	19	767-0759-010	13499	18	16
756-9043-001	13499	1	21	767-0764-008	13499	14	30
757-0228-001	13499	5	21	775-2711-001	13499	5	1
757-0228-001	13499	9	5	855020R	08717	5	17
757-0230-001	13499	5	3	855020R	08717	8	3

LATEST NATIONAL STOCK NUMBER ASSIGNMENTS

STOCK NUMBER	FIGURE NO	ITEM NO	STOCK NUMBER	FIGURE NO	ITEM NO
5310-00-058-2949	11	4	5330-0-824-9130	21	31
5310-00-058-2949	12	4	5330-00-824-9130	22	11
5310-00-058-2949	17	5	5310-00-881-1624	1	24
5310-00-058-2949	18	21	5935-00-883-0218	26	5
5310-00-058-2949	21	21	6625-00-908-7385	5	20
5310-00-058-2949	22	16	6625-00-908-7386	5	13
5305-00-071-1321	14	7	5306-00-924-0654	1	18
6145-00-080-6517	17	36	9535-00-928-3127	10	1
5120-00-198-5401	4	13	5940-00-941-1933	31	5
5975-00-281-0034	31	6	5935-00-954-4470	15	5
5325-00-285-3373	9	12	5935-00-954-4470	16	22
5935-00-617-6837	4	20	5935-00-954-4470	17	1
5310-00-639-7435	9	4	5935-00-954-4470	18	1
5935-00-643-9875	3	10	5935-00-954-4470	19	1
5365-00-717-8566	2	5	5935-00-954-4470	20	1
5935-00-722-4350	26	1	5935-00-954-4470	21	3
6625-00-738-5985	3	1	5935-00-954-4470	22	1
5330-00-824-9130	17	40	5120-00-995-9045	4	12
5330-00-824-9130	18	24			

TM11-6625-564-20P
SECTION IV
NATIONAL STOCK NUMBER AND PART NUMBER INDEX

LATEST PART NUMBER ASSIGNMENTS

PART NUMBER	FSCM	FIG NO	ITEM NO	PART NUMBER	FSCM	FIG NO	ITEM NO
CX10186ARC51X6FT	80058	3	1	SKT41WHITE	98291	22	1
DBMF25S	71768	26	5	UG21E/U	80058	10	
DB-24659	71768	26	1	012-1194-00	13499	9	12
GGGK275	81348	4	12	050	08664	4	13
MS51960-64	96906	14	7	213-141216-00-2303	78189	17	40
SKT41WHITE	98291	15	5	213-141216-00-2303	78189	18	24
SKT41WHITE	98291	16	22	213-141216-00-2303	78189	21	31
SKT41WHITE	98291	17	1	213-141216-00-2303	78189	22	11
SKT41WHITE	98291	18	1	24A	76515	31	5
SKT41WHITE	98291	19	1	26	76545	31	6
SKT41WHITE	98291	20	1	761-7041-001	13499	5	20
SKT41WHITE	98291	21	3	761-7042-001	13499	5	13

ADDITIONAL LATEST NATIONAL STOCK NUMBER ASSIGNMENTS

STOCK NUMBER	FIG NO	ITEM NO	STOCK NUMBER	FIG NO	ITEM NO
6625-00-058-3841	18	18	5310-00-907-0959	17	31
5310-00-190-7693	31	4	5310-00-907-0959	18	31
8105-00-753-4589	4	19	5310-00-907-0959	19	8
5310-00-883-5931	9	23	5310-00-907-0959	20	9
5310-00-907-0959	1	14	5310-00-907-0959	21	11
5310-00-907-0959	9	16	5310-00-907-0959	22	24
5310-00-907-0959	15	18	5935-00-928-3127	10	1
5310-00-907-0959	16	20	6625-00-935-8641	3	13

ADDITIONAL LATEST PART NUMBER ASSIGNMENTS

PART NUMBER	FSCM	FIG NO	ITEM NO	PART NUMBER	FSCM	FIG NO	ITEM NO
024-0137-00	13499	4	19	310-6320-000	79807	18	31
310-0079-000	13499	31	4	310-6320-000	79807	19	8
310-6320-000	79807	1	14	310-6320-000	79807	20	9
310-6320-000	79807	9	16	310-6320-000	79807	21	11
310-6320-000	79807	15	18	310-6320-000	79807	22	24
310-6320-000	79807	16	20	410894-38	96214	9	23
310-6320-000	79807	17	31	761-7006-002	13499	18	18



SOMETHING WRONG WITH THIS MANUAL?

THEN... JOT DOWN THE DOPE ABOUT IT ON THIS FORM, TEAR IT OUT, FOLD IT AND DROP IT IN THE MAIL!

FROM: (YOUR UNIT'S COMPLETE ADDRESS)

Commander
Stateside Army Depot
ATTN: AMSTA-US
Stateside, N.J. 07703

DATE 10 July 1975

PUBLICATION NUMBER

TM 11-5840-340-20P

DATE

23 Jan 78

TITLE

Radar Set AN/PRC-76

BE EXACT... PIN-POINT WHERE IT IS

PAGE NO.	PARA-GRAPH	FIGURE NO.	TABLE NO.
33			
44		19	
45			

IN THIS SPACE TELL WHAT IS WRONG AND WHAT SHOULD BE DONE ABOUT IT:

For item 2, change the NSN to read: 5835-00-134-9186.
Reason: Accuracy.

Identify the cover on the junction box (item no. 5).
Reason: It is a separate item and is not called out on figure 19.

Add the cover of the junction box as an item in the listing for figure 19.
Reason: Same as above.

TEAR ALONG DOTTED LINE

E
L
P
M
A
S

TYPED NAME, GRADE OR TITLE, AND TELEPHONE NUMBER

SSG I. M. DeSpirito 999-1776

SIGN HERE:

SSG I. M. DeSpirito

DA FORM 2028-2
1 AUG 74

P.S.--IF YOUR OUTFIT WANTS TO KNOW ABOUT YOUR MANUAL "FIND," MAKE A CARBON COPY OF THIS AND GIVE IT TO YOUR HEADQUARTERS.

RECOMMENDED CHANGES TO EQUIPMENT TECHNICAL MANUALS



SOMETHING WRONG WITH THIS MANUAL?

THEN... JOT DOWN THE DOPE ABOUT IT ON THIS FORM, TEAR IT OUT, FOLD IT AND DROP IT IN THE MAIL!

FROM: (YOUR UNIT'S COMPLETE ADDRESS)

DATE

PUBLICATION NUMBER

TM 11-6625-564-20P

DATE

29 Mar 79

TITLE MAINTENANCE KITS, ELECTRONIC EQUIPMENT MK-731/ARC-51X & MK-731A/ARC-51X

BE EXACT... PIN-POINT WHERE IT IS

IN THIS SPACE TELL WHAT IS WRONG AND WHAT SHOULD BE DONE ABOUT IT:

PAGE NO.	PARA-GRAPH	FIGURE NO.	TABLE NO.
----------	------------	------------	-----------

TEAR ALONG DOTTED LINE

TYPED NAME, GRADE OR TITLE, AND TELEPHONE NUMBER

SIGN HERE:

DA FORM 2028-2
1 AUG 74

P.S.--IF YOUR OUTFIT WANTS TO KNOW ABOUT YOUR MANUAL "FIND," MAKE A CARBON COPY OF THIS AND GIVE IT TO YOUR HEADQUARTERS.

FILL IN YOUR
UNIT'S ADDRESS

FOLD BACK

DEPARTMENT OF THE ARMY

OFFICIAL BUSINESS
PENALTY FOR PRIVATE USE, \$300

POSTAGE AND FEES PAID
DEPARTMENT OF THE ARMY
DOD-314



Commander
US Army Communications and
Electronics Materiel Readiness Command
ATTN: DRSEL-ME-MQ
Fort Monmouth, New Jersey 07703

TEAR ALONG DOTTED LINE

FOLD BACK

RECOMMENDED CHANGES TO EQUIPMENT TECHNICAL MANUALS



SOMETHING WRONG WITH THIS MANUAL?

THEN...JOT DOWN THE DOPE ABOUT IT ON THIS FORM, TEAR IT OUT, FOLD IT AND DROP IT IN THE MAIL!

FROM: (YOUR UNIT'S COMPLETE ADDRESS)

DATE

PUBLICATION NUMBER

TM11-6625-564-20P

DATE

29 Mar 79

TITLE MAINTENANCE KITS, ELECTRONIC EQUIPMENT MK-731/ARC-51X & MK-731A/ARC-51X

BE EXACT...PIN-POINT WHERE IT IS

IN THIS SPACE TELL WHAT IS WRONG AND WHAT SHOULD BE DONE ABOUT IT:

PAGE NO.	PARA-GRAPH	FIGURE NO.	TABLE NO.
----------	------------	------------	-----------

TEAR ALONG DOTTED LINE

TYPED NAME, GRADE OR TITLE, AND TELEPHONE NUMBER

SIGN HERE:

DA FORM 2028-2
1 AUG 74

P.S.--IF YOUR OUTFIT WANTS TO KNOW ABOUT YOUR MANUAL "FIND," MAKE A CARBON COPY OF THIS AND GIVE IT TO YOUR HEADQUARTERS.

FILL IN YOUR
UNIT'S ADDRESS

FOLD BACK

DEPARTMENT OF THE ARMY

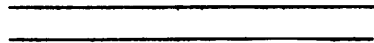

OFFICIAL BUSINESS

PENALTY FOR PRIVATE USE, \$300

POSTAGE AND FEES PAID
DEPARTMENT OF THE ARMY
DOD-314



Commander
US Army Communications and
Electronics Materiel Readiness Command
ATTN: DRSEL-ME-MQ
Fort Monmouth, New Jersey 07703

TEAR ALONG DOTTED LINE

FOLD BACK

REVERSE OF DA FORM 2028-2

RECOMMENDED CHANGES TO EQUIPMENT TECHNICAL MANUALS



SOMETHING WRONG WITH THIS MANUAL?

THEN...JOT DOWN THE DOPE ABOUT IT ON THIS FORM, TEAR IT OUT, FOLD IT AND DROP IT IN THE MAIL!

FROM: (YOUR UNIT'S COMPLETE ADDRESS)

DATE

PUBLICATION NUMBER

TM 11-6625-564-20P

DATE

29 Mar 79

TITLE MAINTENANCE KITS, ELECTRONIC EQUIPMENT MK-731/ARC-51X & MK-731A/ARC-51X

BE EXACT...PIN-POINT WHERE IT IS

IN THIS SPACE TELL WHAT IS WRONG AND WHAT SHOULD BE DONE ABOUT IT:

PAGE NO.	PARA-GRAPH	FIGURE NO.	TABLE NO.

TEAR ALONG DOTTED LINE

TYPED NAME, GRADE OR TITLE, AND TELEPHONE NUMBER

SIGN HERE:

FILL IN YOUR
UNIT'S ADDRESS

FOLD BACK

DEPARTMENT OF THE ARMY

OFFICIAL BUSINESS
PENALTY FOR PRIVATE USE, \$300

POSTAGE AND FEES PAID
DEPARTMENT OF THE ARMY
DOD-314



Commander
US Army Communications and
Electronics Materiel Readiness Command
ATTN: DRSEL-ME-MQ
Fort Monmouth, New Jersey 07703

TEAR ALONG DOTTED LINE

FOLD BACK

By Order of the Secretary of the Army:

BERNARD W. ROGERS
General, United States Army
Chief of Staff

Official:

J.C. PENNINGTON
Brigadier General, United States Army
The Adjutant General

DISTRIBUTION:

To be distributed in accordance with DA Form 12-36, Direct and General Support maintenance requirements for AN/ARC-51.

DEPARTMENT OF THE ARMY
US ARMY AG PUBLICATIONS CENTER
1655 WOODSON ROAD
ST. LOUIS, MISSOURI 63114

OFFICIAL BUSINESS
PENALTY FOR PRIVATE USE \$300

POSTAGE AND FEES PAID
DEPARTMENT OF THE ARMY
DOD 314

